



专业化、现代化、规范化
Specialization, Modernization, Standardization

ØJPLS valves

天津普洛斯阀门有限公司 TIANJIN PULOS VALVE CO., LTD.

地址: 天津市津南区北闸口镇火炬路3号-1号
Add: No. 3-1, Huoju Road, BeiZhakou Town, Jinnan District, Tianjin, China

电话: 022-88622721
Tel: +86-22-88622721

传真: 022-88622721
Fax: +86-22-88622721

手机: 18702268666
Mob: +86-18702268666

<http://www.plsvalve.com/>
E-mail: William@plsvalve.com



企业官网



Website



天津普洛斯阀门有限公司
TIANJIN PULOS VALVE CO., LTD.

企业简介 Brief Introduction

天津普洛斯阀门有限公司工厂地址座落于天津市津南区，是一家集科研、设计、生产、销售及售后服务为一体的专业阀门制造商。公司成立以来发展迅速，业务不断发展壮大，公司主营产品有中线蝶阀，软密封蝶阀，脱硫蝶阀，污水处理蝶阀，防结露蝶阀等等。

产品通径范围：1"-88"/DN15-DN2200(可依据客户要求定制生产更大口径)，包含了不锈钢304、/316、316L，铸钢WCB，球墨铸铁QT450，镍铝青铜C95400、C95800，哈氏合金钢2205、2507、4592，铝合金等材质类别，产品广泛应

The factory address of Tianjin Pulos Valve Co.,Ltd. is located in Jinnan District, Tianjin City, China, which is a professional valve manufacturer integrating scientific research, design, production, sales and after-sales service. The company has developed rapidly since its establishment, and business has continued to grow. The company's main products include central line butterfly valves, soft seal butterfly valves, desulfurization butterfly valves, sewage treatment butterfly valves, anti-condensation butterfly valves, etc.

Nominal Diameter : 1/2"-48"/DN15-DN1200 (Larger upon request)
Pressure Rating: 150Lb-2500Lb, PN6-PN420. Main Materials: ANSI/ASTM WCB (A105), WC1 (F1), C5 (F5), WC6 (F11), WC9 (F22), LCB (LF2), CF8 (304), CF8M (316), CF3 (304L), CF3M (316L), CN7M (B462/NO8020), Monel, Duplex, Inconel, Hastelloy, Cast iron, Ductile iron, etc. Products are widely used in water conservancy, power plants,

用于水利，电厂，污水处理厂，造纸厂等行业，远销国内外。公司自创建伊始就本着高标准、高科技、高起点、大规模的经营战略；拥有先进的生产设备、精湛的生产技术、严密的检测手段；并且已通过ISO9001国际质量体系认证，ISO14001国际环境体系认证，ISO45001:2018职业健康安全管理体系认证，不断提高产品的核心竞争力和客户满意度。在现如今市场价格竞争激烈的环境下，我公司始终秉承着“培养优秀员工、生产优质产品、提供优良服务”的企业宗旨，坚持不懈的追求优良品质，为新老客户解决后顾之忧，希望能与您合作共赢，共创美好明天。

sewage treatment plants, paper mills and other industries, and are exported to local and abroad. Since its establishment, the company has been following a high-standard, high-tech, high starting point, and large-scale business strategy; it has advanced production equipment, superb production technology, and strict testing methods; and has passed ISO9001 international quality system certification, ISO14001 international environment System certification, ISO45001:2018 occupational health and safety management system certification, continuously improve the core competitiveness of products and customer satisfaction. Now in the fierce market price competition environment, our company always adheres to the tenet of "cultivating excellent employees, producing high-quality products and providing excellent services", persistently pursues excellent quality, solves the worries for new and old customers, and hopes to cooperate with you for win-win cooperation relationship and create a better tomorrow together.



资质荣誉 Qualification Honor

普洛斯阀门以市场为导向，以客户为中心，以质量求生存，以效率求发展，求真务实，开拓创新，所生产的优质产品服务于众多客户，并获得良好的口碑，深受客户一致好评！

PULOS valve is market-oriented, customer-oriented, strives for survival by quality, strives for development by efficiency, is pragmatic, develops and innovates. The quality products produced by pross valve serve many customers and have won good public praise and been well received by customers!



普洛斯一直坚持严格控制把关每一个环节、每一道工序，从设计研发到生产作业各个环节的质量状况。检测系统流程均按照国际先进的行业标准要求，自产品设计就纳入一套极其严谨、精确的程序之中，从设计、采购、制造、试验、包装到运输，每个环节都要经历苛刻的检测程序，将精度控制到最严密，产品品质控制到最优异，对每一细微之处的精益求精，都控制到最完美，让客户在使用的同时，深切感受到我们严谨务实的品质宗旨……

PULOS has been adhering to the strict control of every link, every process, from design and development to the quality of the production operation of each link. Detection system processes are in accordance with the international advanced industry standard requirements, from product design into an extremely rigorous, accurate procedure, from the design, procurement, manufacturing, testing, packaging to shipping, every link have to undergo rigorous testing procedures, the precision control to the most rigorous, product quality control to the most excellent, keep improving every tiny point, control to the most perfect, let the customer in use at the same time, deeply felt our rigorous pragmatic quality objective...



产品检测 Product Testing

为了提供高品质产品，公司配置了先进的检测设备以及完善的检测手段，建立了一支严格要求的品质管理队伍，实现了从原材料检测，生产过程检测，产品及应用全过程的质量控制。

In order to provide high quality products, the company has equipped with advanced testing equipment and perfect testing methods, established a strict quality management team, and realized the quality control of the whole process from raw material testing, production process testing, products and applications.

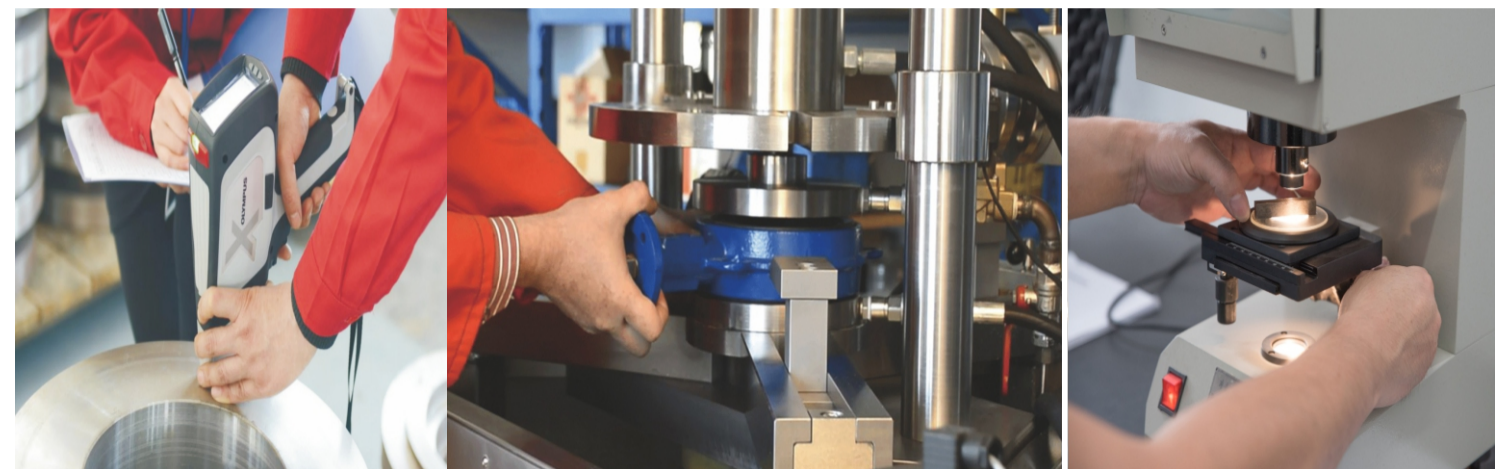

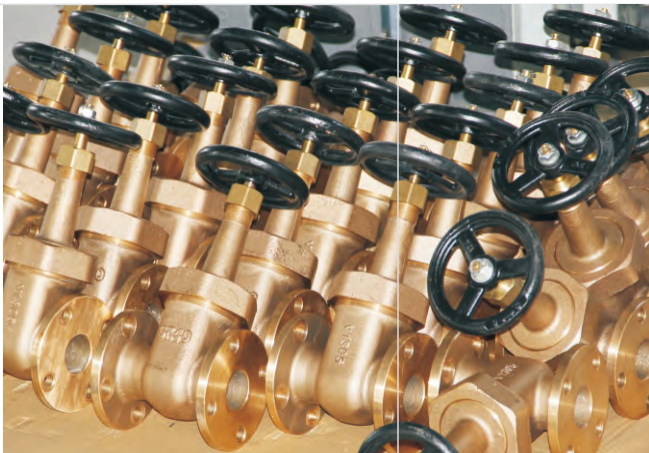

目录Contents

JIS MARINE VALVE 目标船用阀门

船用短法兰蝶阀	Marine short flange butterfly Valve	01
船用半凸耳蝶阀	Marine semi-lug butterfly Valve	02
船用V系列蝶阀	Marine V series butterfly Valves	03
船用全凸耳蝶阀	Marine full lug butterfly Valve	04
蝶式对夹止回阀	Wafer check Valve	05
铸铁球形截止阀5K	F7305 Cast Iron 5K Globe Valves	06
铸铁球形截止阀10K	F7307 Cast Iron 10K Globe Valves	
铸铁球形截止阀16K	F7309 Cast Iron 16K Globe Valves	
铸铁角式截止阀5K	F7306 Cast Iron 5K Angle Valves	07
铸铁角式截止阀10K	F7308 Cast Iron 10K Angle Valves	
铸铁角式截止阀16K	F7310 Cast Iron 16K Angle Valves	
铸铁球形截止止回阀5K	F7353 Cast Iron 5K Screw-down Check Globe Valves	08
铸铁球形截止止回阀10K	F7375 Cast Iron 10K Screw-down Check Globe Valves	
铸铁球形截止止回阀16K	F7377 Cast Iron 16K Screw-down Check Globe Valves	
铸铁角式截止止回阀5K	F7354 Cast Iron 5K Screw-down Check Angle Valves	09
铸铁角式截止止回阀10K	F7376 Cast Iron 10K Screw-down Check Angle Valves	
铸铁角式截止止回阀16K	F7378 Cast Iron 16K Screw-down Check Angle Valves	
铸铁球形升降式止回阀	F7358 Cast Iron 5K Lift Check Globe Valves	10
铸铁角式升降式止回阀	F7359 Cast Iron 5K Lift Check Angle Valves	
铸铁旋启式止回阀5K	F7372 Cast Iron 5K Swing Check Valves	11
铸铁旋启式止回阀10K	F7373 Cast Iron 10K Swing Check Valves	
铸铁闸阀5K	F7363 Cast Iron 5K Gate Valves	12
铸铁闸阀10K	F7364 Cast Iron 10K Gate Valves	
铸铁闸阀16K	F7369 Cast Iron 16K Gate Valves	
铸铁软管阀门(球形)	F7333 Cast Iron Globe Hose Valves	13
铸铁软管阀门(角式)	F7333 Cast Iron Angle Hose Valves	
铸铁Y型过滤器	F7220 Cast Iron Y Type Strainer	14
泥箱	F7203 Marine Mud Boxes L Type	15
水过滤器	F7121 Shipbuilding-Can Water Filters	16
油过滤器	F7209 Shipbuilding-simplex Oil Strainers	17
空气管头	Cast Iron Air Vent Head	18
尼古拉式空气管头	53-ON AIR PIPE HEAD	19
青铜球形截止阀5K	F7301 Bronze 5K Globe Valves	20
青铜球形截止阀16K	F7303 Bronze 16K Globe Valves	
青铜角式截止阀5K	F7302 Bronze 5K Angle Valves	21
青铜角式截止阀16K	F7304 Bronze 16K Angle Valves	
青铜球形截止止回阀5K	F7351 Bronze 5K Screw-down Check Globe Valves	22
青铜球形截止止回阀16K	F7409 Bronze 16K Screw-down Check Globe Valves	

JIS MARINE VALVE 目标船用阀门

150磅级青铜球形截止阀5K	Class 150 Bronze 5K Globe Valves Open/close Indicator	23
150磅级青铜球形截止阀10K	Class 150 Bronze 10K Globe Valves Open/close Indicator	
150磅级青铜球形截止止回阀5K	Class 150 Bronze 5K SDNR Globe Valves Open/close Indicator	24
150磅级青铜球形截止止回阀10K	Class 150 Bronze 10K SDNR Globe Valves Open/close Indicator	
150磅级青铜闸阀5K	Class 150 Bronze 5K Gate Valves Open/close Indicator	25
150磅级青铜闸阀10K	Class 150 Bronze 10K Gate Valves Open/close Indicator	
150磅级青铜球阀	Class 150 Flange Bronze Ball Valves	26
青铜闸阀5K	F7367 Bronze 5K Rising Stem Type Gate Valves	27
青铜闸阀10K	F7368 Bronze 10K Rising Stem Type Gate Valves	
青铜法兰旋塞阀	F7381 Bronze 5K Flanged Cocks Valves	28
青铜旋启式止回阀	F7371 Bronze 5K/10K Swing Check Valves	29
青铜旋启式止回阀	F7371 Bronze 5K/10K Swing Check Valves	30
青铜软管阀门(球形)	F7334 Bronze Globe Hose Valves	31
青铜软管阀门(球形)	F7334 Bronze Globe Hose Valves	32
青铜软管阀门(角型)	F7334 Bronze Hose Angle Valves	33
青铜软管阀门(角型)	F7334 Bronze Hose Angle Valves	34
铜Y型过滤器	F7220Q Bronze Y Type Strainer	35
自闭闸阀式短测深管头	F3019 Self-closing Gate Valve Heads For Sounding Pipe	36
自闭式放卸阀	F7398 Shipbuilding-fuel Oil Tank Self-closing Drain Valves U/F Type	37
快速切断阀	F7399 Fuel Oil Tank Emergency Shut-off Valves	38
青铜球形截止阀	F7388 Bronze 20K Globe Valves S/U Type	39
铸钢球形截止阀5K	F7311 Cast Steel 5K Globe Valves	40
铸钢球形截止阀10K	F7319 Cast Steel 10K Globe Valves	
铸钢球形截止阀20K	F7313 Cast Steel 20K Globe Valves	
铸钢球形截止止回阀5K	F7311C Cast Steel 5K Screw-down Check Globe Valves	41
铸钢球形截止止回阀10K	F7471 Cast Steel 10K Screw-down Check Globe Valves	
铸钢球形截止止回阀20K	F7473 Cast Steel 20K Screw-down Check Globe Valves	
铸钢角式截止阀5K	F7312 Cast Steel 5K Angle Valves	42
铸钢角式截止阀10K	F7320 Cast Steel 10K Angle Valves	
铸钢角式截止阀20K	F7314 Cast Steel 20K Angle Valves	
铸钢角式截止止回阀5K	F7312C Cast Steel 5K Screw-down Check Angle Valves	43
铸钢角式截止止回阀10K	F7472 Cast Steel 10K Screw-down Check Angle Valves	
铸钢角式截止止回阀20K	F7474 Cast Steel 20K Screw-down Check Angle Valves	
铸钢截止阀40K	F7317 marine cast steel 40K globe valve	44
铸钢截止阀40K	F7318 marine cast steel 40K angle valve	
铸钢闸阀5K	F7363C Cast Steel 5K Gate Valves	45
铸钢闸阀10K	F7366 Cast Steel 10K Gate Valves	
铸钢球形防浪阀	F3060 Cast Steel Globe Storm Valves	46
铸钢角式防浪阀	F3060R Cast Steel Angle Storm Valves	

船用短法三蝶阀 Marine short flange butterfly valve

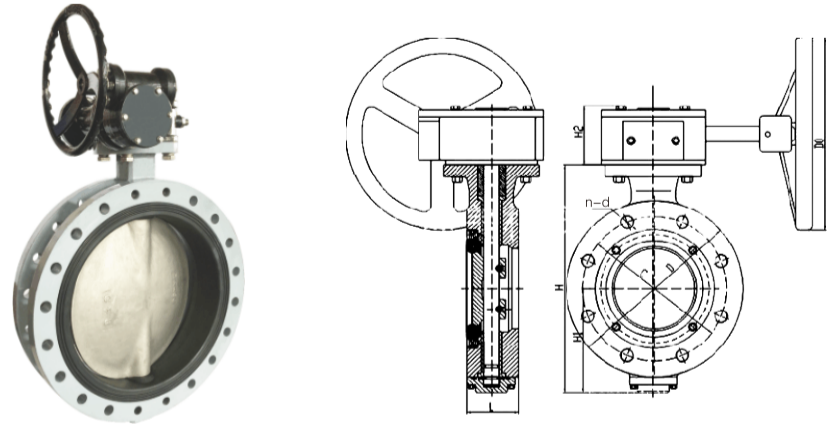

主要零件及材料 Material of main parts

零件名称 Part name	材料 Material
阀体 Body Materials	球铁 Ductile iron, 铸钢 Cast steel, 不锈钢 Stainless Steel, 双向钢 Two-way steel, 青铜 C954 Bronze C954
阀板 Plate Materials	SUS 304, SUS 316, SUS 2205, SUS 2507, SUS 1.4529 C954
阀轴 Shaft Materials	45# 416 SS304 SS316
阀座 Seat Materials	NBR, EPDM, VITON, PTFE
驱动方式 Operate	手柄 Manual, 蜗轮 Worm gear, 气动 Pneumatic, 电动 Electric-Motorized

设计标准 Valve design

技术规范 Technical specification	
设计标准 Valve design	API 609
结构长度 Face to Face	JIS B2002
压力试验 Pressure test	JIS B2003
连接法兰 Flange Drilling	JIS B2212 JIS B2213 JIS B2214

主要外形及连接尺寸 Main external and connecting dimensions(mm)

公称压力 Nominal pressure (MPa)	公称通径 Nominal diameter (mm)	结构及法兰尺寸 Structure & Flange Dimension									螺孔 Hole of Nut					
		ISO (GB2501-89)			JIS			ISO (GB569-65)			ISO		JIS		GB	
		L	D	D1	L	D	D1	L	D	D1	n-d	n-Th.	n-d	n-Th.	n-d	n-Th.
1.0	50	43	165	125	43	155	120	43	135	103	4-18	4-M16	4-19	4-M16	6-16	6-M14
	65	45	185	145	45	175	140	45	155	123	4-18	4-M16	4-19	4-M16	6-16	6-M14
	80	60	200	160	60	185	150	60	170	138	8-18	4-M16	8-19	8-M16	8-16	8-M14
	100	60	220	180	60	210	175	60	190	158	8-18	4-M16	8-23	8-M20	8-16	8-M14
	125	100	250	210	100	250	210	100	215	183	8-18	4-M16	8-23	8-M16	10-16	10-M14
	150	100	285	240	100	280	240	100	240	208	8-22	4-M20	8-23	8-M20	12-16	12-M14
	200	100	340	295	100	330	290	100	310	273	8-22	4-M20	12-23	12-M20	12-19	12-M16
	250	110	395	350	110	400	355	110	380	336	12-22	4-M20	12-25	12-M22	14-23	14-M20
	300	110	445	400	110	445	400	110	435	391	12-22	4-M20	16-25	16-M22	16-23	16-M20
	350	120	505	460	120	490	445	120	485	441	16-22	4-M20	16-25	16-M22	18-23	18-M20
	400	130	565	515	130	560	510	130	545	496	16-26	4-M24	16-27	16-M24	18-27	18-M24
	450	150	615	565	150	620	565	150	600	551	20-28	4-M24	20-27	20-M24	20-27	20-M24
500	160	670	620	160	675	620	160	650	601	20-28	4-M24	20-27	20-M24	20-27	20-M24	
600	170	730	675	170	745	680	170			20-31	4-M27	24-33	24-M30			

船用半凸耳蝶阀 Marine semi-lug butterfly Valve

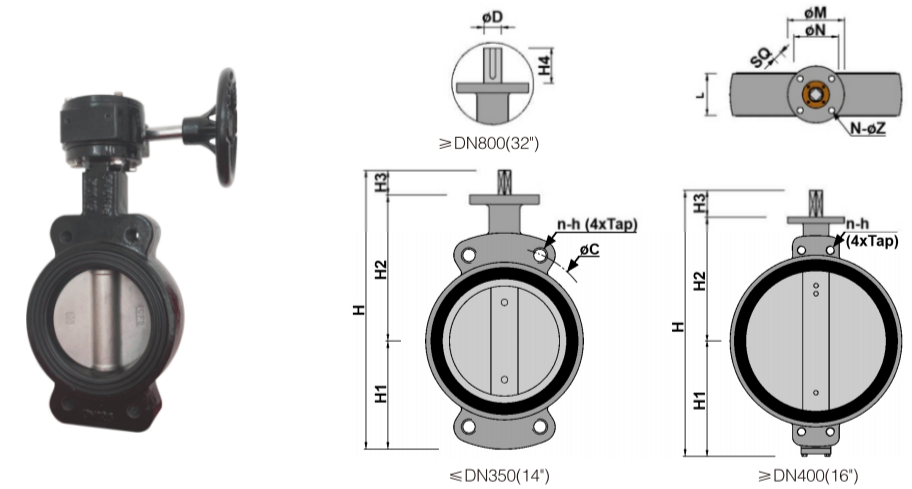

主要零件及材料 Material of main parts

零件名称 Part name	材料 Material
阀体 Body Materials	球铁 Ductile iron, 铸钢 Cast steel, 不锈钢 Stainless Steel, 双向钢 Two-way steel, 青铜 C954 Bronze C954
阀板 Plate Materials	SUS 304, SUS 316, SUS 2205, SUS 2507, SUS 1.4529 C954
阀轴 Shaft Materials	45# 416 SS304 SS316
阀座 Seat Materials	NBR, EPDM, VITON, PTFE

设计标准 Valve design

技术规范 Technical specification	
设计标准 Valve design	API 609-83
结构长度 Face to Face	JIS B2002
压力试验 Pressure test	JIS B2003
连接法兰 Flange Drilling	JIS B2212 JIS B2213 JIS B2214

主要外形及连接尺寸 Main external and connecting dimensions DN 50-1200, DIN PN10, PN16, ANSI 150 (mm)

DN	L	H	H1	H2	H4	Stem				Top Flange				kg	DIN PN10		DIN PN16		ANSI 150	
						Round		Square		ISO 5211	N	M	n x o		C	n-h	C	n-h	C	n-h
						D	Key	SQ	H3											
50	43	216	55	128	33	14	5 x 5	9	33	F07	70	90	4 x 9	10	125	4 x M16	125	4 x M16	120.5	4 x 5/8"
65	46	239	66	140	33	14	5 x 5	9	33	F07	70	90	4 x 9	11	145	4/8 x M16	145	4/8 x M16	139.5	4 x 5/8"
80	46	258	75	150	33	14	5 x 5	9	33	F07	70	90	4 x 9	11	160	8 x M16	160	8 x M16	152.5	4 x 5/8"
100	52	293	95	165	33	19	6 x 6	12	33	F07	70	90	4 x 9	12	180	8 x M16	180	8 x M16	190.5	8 x 5/8"
125	56	326	115	178	33	19	6 x 6	12	33	F07	70	90	4 x 9	13	210	8 x M16	210	8 x M16	216.0	8 x 3/4"
150	56	353	130	190	33	19	6 x 6	12	33	F07	70	90	4 x 9	15	240	8 x M20	240	8 x M20	241.5	8 x 3/4"
200	60	435	155	230	50	22	8 x 7	17	50	F10	102	125	4 x 12	19	295	8 x M20	295	12 x M20	298.5	8 x 3/4"
250	68	535	215	270	50	25	8 x 7	17	50	F10	102	125	4 x 12	37	350	12 x M20	355	12 x M24	362.0	12 x 7/8"
300	78	611	251	310	50	32	10 x 8	22	50	F10	102	125	4 x 12	47	400	12 x M20	410	12 x M24	432.0	12 x 7/8"
350	78	655	270	335	50	32	10 x 8	27	50	F10	140	175	4 x 12	67	460	16 x M20	470	16 x M24	476.0	12 x 1"
400	102	755	325	370	60	40	12 x 8	27	60	F14	140	175	4 x 18	91	515	16 x M24	525	16 x M27	539.5	16 x 1"
450	114	797	347	390	60	40	12 x 8	27	60	F14	140	175	4 x 18	104	565	20 x M24	585	20 x M27	578.0	16 x 1 1/8"
500	127	883	383	420	80	45	14 x 9	36	80	F16	165	210	4 x 22	154	620	20 x M24	650	20 x M30	635.0	20 x 1 1/8"
600	154	1028	453	495	80	65	20 x 12	50	80	F16	165	210	4 x 22	240	725	20 x M27	770	20 x M33	749.5	20 x 1 1/4"
700	165	1150	515	555	80	65	20 x 12	50	90	F16	165	210	4 x 22	305	840	24 x M27	840	24 x M33	863.5	28 x 1 1/4"
800	190	1352	592	640	90	65	20 x 12	-	-	F25	254	300	8 x 18	403	950	24 x M30	950	24 x M36	978.0	28 x 1 1/2"
900	203	1488	658	700	130	80	22 x 14	-	-	F25	254	300	8 x 18	607	1050	28 x M30	1050	28 x M36	1086.0	32 x 1 1/2"
1000	216	1645	725	770	150	95	25 x 14	-	-	F30	298	350	8 x 23	829	1160	28 x M33	1170	28 x M39	1200.0	36 x 1 1/2"

船用V系列蝶阀 Marine V series butterfly valves

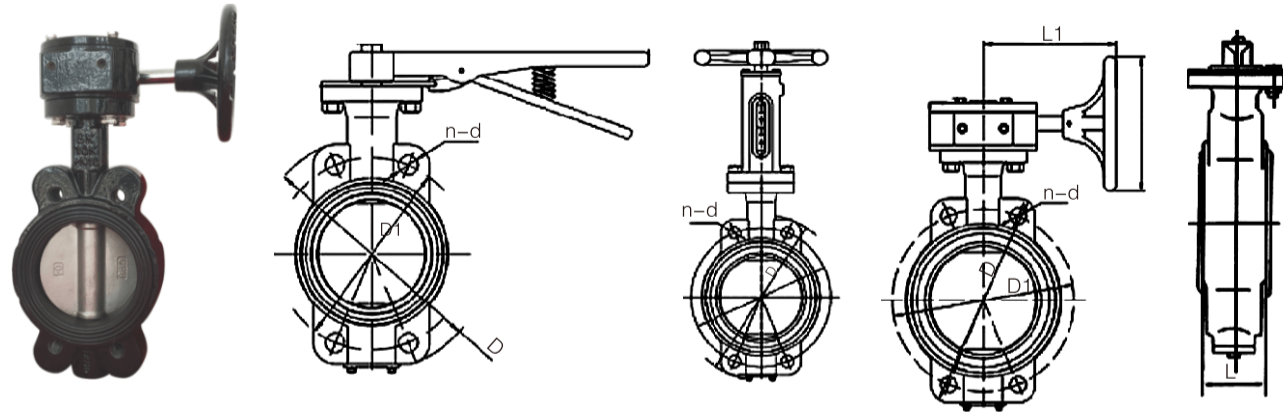

主要零件及材料 Material of main parts

零件名称 Part name	材料 Material
阀体 Body Materials	球铁 Ductile iron, 铸钢 Cast steel, 不锈钢 Stainless Steel, 双向钢 Two-way steel, 青铜C954 Bronze C954
阀板 Plate Materials	SUS 304, SUS 316, SUS 2205, SUS 2507, SUS 1.4529 C954
阀轴 Shaft Materials	45# 416 SS304 SS316
阀座 Seat Materials	NBR, EPDM, VITON, PTFE

设计标准 Valve design

技术规范 Technical specification	
设计标准 Valve design	API 609-83
结构长度 Face to Face	JIS B2002
压力试验 Pressure test	JIS B2003
连接法兰 Flange Drilling	JIS B2212 JIS B2213 JIS B2214

主要外形及连接尺寸 Main external and connecting dimensions(mm)

公称压力 Nominal pressure (MPa)	公称通径 Nominal diameter (mm)	结构及法兰尺寸 Structure & Flange Dimension								螺孔 Hole of Nut											
		ISO (GB2501-89)				JIS				ISO (GB569-65)				ISO		JIS 10K		JIS 5K		GB	
		L	D	D1	尺寸 Size	L	D	D1	D	D1	L	D	D1	n	Th.	n	Th.	n	Th.	n	Th.
1.0	50	40	165	125	40	155	120	130	105	43	135	103	4	M16	4	M16	4	M12	6	M14	
	65	40	185	145	40	175	140	155	130	46	155	123	4	M16	4	M16	4	M12	6	M14	
	80	60	200	160	60	185	150	180	145	46	170	138	8	M16	8	M16	4	M16	8	M14	
	100	60	220	180	60	210	175	200	165	52	190	158	8	M16	8	M16	8	M16	8	M14	
	125	60	250	210	60	250	210	235	200	56	215	183	8	M16	8	M20	8	M16	10	M14	
	150	70	285	240	70	280	240	265	230	56	240	208	8	M20	8	M20	8	M16	12	M14	
	200	80	340	295	80	330	290	320	280	60	310	273	8	M20	12	M20	8	M20	12	M16	
	250	90	395	350	90	400	355	385	345	68	380	336	12	M20	12	M22	12	M20	14	M20	
	300	90	445	400	90	445	400	430	390	78	435	391	12	M20	16	M22	12	M20	16	M20	
	350	100	505	460	100	490	445	480	435	78	485	441	16	M20	16	M22	12	M22	18	M20	
	400	110	565	515	110	560	510	540	495	102	545	496	16	M24	16	M24	16	M22	18	M24	
	450	130	615	565	130	620	565	605	555	114	600	551	20	M24	20	M24	16	M22	20	M24	
500	140	670	620	140	675	620	655	605	127	650	601	20	M24	20	M24	20	M22	20	M24		
600	160	780	725	160	795	730	770	715				20	M27	24	M30	20	M24				

船用全凸耳蝶阀 Marine full lug butterfly valve

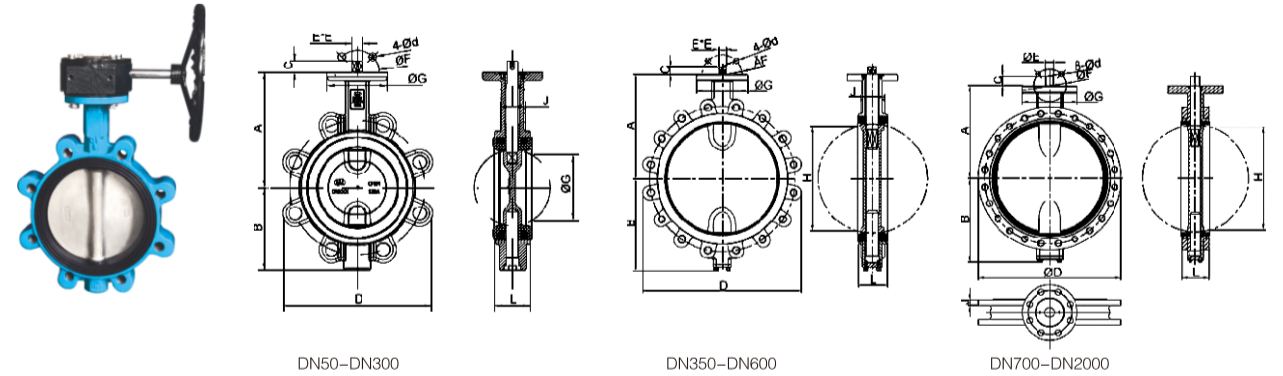

主要零件及材料 Material of main parts

零件名称 Part name	材料 Material
阀体 Body Materials	球铁 Ductile iron, 铸钢 Cast steel, 不锈钢 Stainless Steel, 双向钢 Two-way steel, 青铜C954 Bronze C954
阀板 Plate Materials	球墨铸铁、不锈钢、铝青铜、碳钢、氟橡胶 Ductile iron, Stainless steel, Aluminum bronze, Carbon steel, Fluororubber
阀轴 Shaft Materials	45# 416 SS304 SS316
阀座 Seat Materials	NBR, EPDM, VITON, PTFE

设计标准 Valve design

技术规范 Technical specification	
设计标准 Valve design	GB/T12238 ISO 10631
结构长度 Face to Face	GB/T12221 ISO 5752
压力试验 Pressure test	GB/T13927 JB/T9092 ISO5028 BS 5755-1
连接法兰 Flange Drilling	GB/T17241 JIS B2212 JIS B2220 JIS B2210 A NSI B16.5 ANSI B16.47 ISO7005-2

主要外形及连接尺寸 Main external and connecting dimensions(mm)

Size		A	B	C	D	E	F	d	G	H	J	L	WT(kg)
mm	in												
50	2"	126	78	13.5	117	9	50	8	70	31	34	43	2.8
65	2 1/2"	134	84	13.5	131	9	50	8	70	45	36	46	3.7
80	3"	138	92	13.5	176	9	50	8	70	64	36	46	5.1
100	4"	167	114	13.5	206	11	70	10	90	91	40	52	6.9
125	5"	180	129	17.5	236	14	70	10	90	110	44	56	9.3
150	6"	203	144	17.5	258	14	70	10	90	146	44	56	10.5
200	8"	228	179	24.5	321	17	102	12	125	193	50	60	17.4
250	10"	266	216	25	395	22	102	12	125	241	57	68	28.1
300	12"	291	247	25	461	22	102	12	125	292	66	78	40
350	14"	332	273	30	511	27	125	14	150	329	62	78	55
400	16"	363	317	30	580	27	125	14	150	376	84	102	85
450	18"	397	348	39	630	36	140	18	175	425	94	114	114
500	20"	425	393	39	700	36	140	18	175	475	110	127	144
600	24"	498	453	49	823	46	165	22	210	573	120	154	227
700	28"	626	531	90	928	63.1	254	18	300	674	54	165	342
750	30"	660	564	90	984	63.1	254	18	300	727	54	165	400
800	32"	666	601	90	1061	63.1	254	18	300	771	60	190	485
900	36"	722	660	110	1170	74.7	254	18	300	839	60	203	605
1000	40"	806	728	120	1290	83.7	298	22	350	939	60	216	776
1100	44"	826	771	140	1404	94.7	298	22	350	1036	50	255	985
1200	48"	941	874	150	1511	104.7	298	22	350	1137	62	276	1190
1400	56"	1000	940	175	1685	139.9	356	32	415	1351	62	279	1380
1600	64"	1155	1085	195	1930	160	356	32	415	1548	65	318	2054
1800	72"	1200	1170	195	2170	174.5	406	39	475	1703	70	356	3075
2000	80"	1363	1360	245	2345	199	406	39	475	1938	75	406	4500

蝶式对夹止回阀 Wafer check Valve

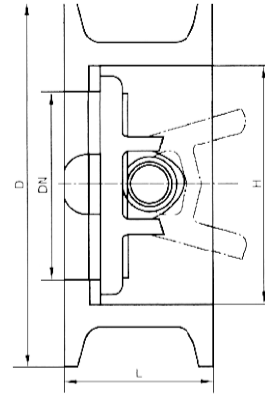

主要零件材质 Material Specifications

部件 Parts	材料 Material
阀体 Body	灰铸铁CI、球墨铸铁DI
阀瓣 Disc	灰铸铁CI、球墨铸铁DI、304、316、铜bronze
阀座 Seat	橡胶 EPDM/NBR
阀杆 Stem	不锈钢 Stainless steel
弹簧 Spring	不锈钢 Stainless steel

设计标准 Valve design

技术规范 Technical specification	
结构长度 Face to Face	ISO
连接法兰 Flange Drilling	DIN/BS/JIS/ANSI
压力 Pressure	PN10/PN16/10K/150LB

主要外形及连接尺寸 Main external and connecting dimensions(mm)

DN	1.0MPa			1.6MPa			2.5MPa		
	L	D	H	L	D	H	L	D	H
40	43	92	55	43	92	55	43	92	55
50	43	107	65.5	43	107	65.5	43	107	65.5
65	46	127	81	46	127	81	46	127	81
80	64	142	95	64	142	95	64	142	95
100	64	162	117.5	64	162	117.5	64	166	117.5
125	70	192	145.5	70	192	145.5	70	192	145.5
150	76	218	170.5	76	218	170.5	76	222	170.5
200	89	273	227.5	89	273	227.5	89	282	227.5
250	114	328	266	114	329	266	114	337	266
300	114	378	312	114	384	312	114	397	312
350	127	438	361	127	444	361	127	454	361
400	140	489	406	140	495	406	140	511	406
450	152	539	450	152	555	450	152	560	450
500	152	594	505	152	617	505	152	620	505
600	178	695	624	178	734	624	178	727	624
700	229	804	736	229	804	736	229	829	736
800	241	910	842	241	910	842	241	938	842
900	241	1010	945	241	1010	945	241	1038	945
1000	300	1125	1050	300	1125	1050	300	1150	1050

铸铁球形截止阀5K F7305 Cast Iron 5K Globe Valves
 铸铁球形截止阀10K F7307 Cast Iron 10K Globe Valves
 铸铁球形截止阀16K F7309 Cast Iron 16K Globe Valves

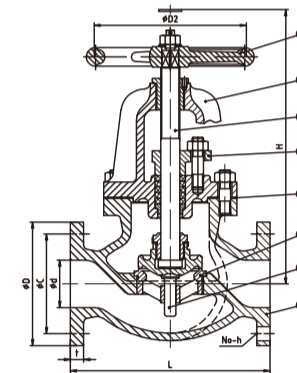

材料表 MATERIALS TABLE

序号	零件名称	材料		NAME OF PART	MATERIAL	
		CLASS B	CLASS S		CLASS B	CLASS S
1	阀体	HT200		BODY	FC200	
2	阀盖	HT200		BONNET	FC200	
3	阀盘	ZCuSn5Pb5Zn5	ZG2Cr13	DISC	BC6	SUS 420
4	阀座	ZCuSn5Pb5Zn5	ZG2Cr13	VALVE SEAT	BC6	SUS 420
5	阀杆	HPb59-1	ZG2Cr13	STEM	C377IBD OR BE	SUS 420
6	压盖	ZCuSn5Pb5Zn5		GLAND PACKING	BC6	
7	垫片	非石棉		GASKET	NON-ASBESTOS	
8	手轮	HT200		HANDWHEEL	FC200	

尺寸表 SIZE TABLE (7305)

DN	d	L	D	C	NO.	h	t	H	D2
50	50	210	130	105	4	15	16	270	160
65	65	250	155	130	4	15	18	300	180
80	80	280	180	145	4	19	18	310	180
100	100	340	200	165	8	19	20	360	224
125	125	410	235	200	8	19	20	390	250
150	150	480	265	230	8	19	22	445	280
200	200	570	320	280	8	23	24	530	315
250	250	740	385	345	12	23	26	650	355
300	300	840	430	390	12	23	28	740	400
350	335	940	480	435	12	25	30	840	500
400	380	1050	540	495	16	25	30	940	600

尺寸表 SIZE TABLE (7307)

DN	d	L	D	C	NO.	h	t	H	D2
50	50	220	155	120	4	19	20	285	160
65	65	270	175	140	4	19	22	310	200
80	80	300	185	150	8	19	22	320	200
100	100	350	210	175	8	19	24	370	250
125	125	420	250	210	8	23	24	420	280
150	150	490	280	240	8	23	26	470	315
200	200	570	330	290	12	23	26	555	355
250	250	740	400	355	12	25	30	680	450
300	300	840	445	400	16	25	32	770	500

尺寸表 SIZE TABLE (7309)

DN	d	L	D	C	NO.	h	t	H	D2
50	50	220	155	120	8	19	20	285	160
65	65	270	175	140	8	19	22	310	200
80	80	300	200	160	8	23	24	340	224
100	100	350	225	185	8	23	26	385	250
125	125	430	270	225	8	25	26	455	315
150	150	500	305	260	12	25	28	510	355
200	200	570	350	305	12	25	30	630	450

铸铁角式截止阀5K F7306 Cast Iron 5K Angle Valves
 铸铁角式截止阀10K F7308 Cast Iron 10K Angle Valves
 铸铁角式截止阀16K F7310 Cast Iron 16K Angle Valves

材料表 MATERIALS TABLE

序号	零件名称	材料		NAME OF PART	MATERIAL	
		CLASS B	CLASS S		CLASS B	CLASS S
1	阀体	HT200		BODY	FC200	
2	阀盖	HT200		BONNET	FC200	
3	阀盘	ZCuSn5Pb5Zn5	ZG2Cr13	DISC	BC6	SUS 420
4	阀座	ZCuSn5Pb5Zn5	ZG2Cr13	VALVE SEAT	BC6	SUS 420
5	阀杆	HPb59-1	ZG2Cr13	STEM	C377IBD OR BE	SUS 420
6	压盖	ZCuSn5Pb5Zn5		GLAND PACKING	BC6	
7	垫片	非石棉		GASKET	NON-ASBESTOS	
8	手轮	HT200		HANDWHEEL	FC200	

尺寸表 SIZE TABLE (7306)

DN	d	L	D	C	NO.	h	t	H	D2
50	50	100	130	105	4	15	16	240	160
65	65	115	155	130	4	15	18	255	180
80	80	130	180	145	4	19	18	265	180
100	100	150	200	165	8	19	20	310	224
125	125	170	235	200	8	19	20	330	250
150	150	190	265	230	8	19	22	380	280
200	200	220	320	280	8	23	24	450	315
250	250	275	385	345	12	23	26	540	355
300	300	310	430	390	12	23	28	610	400
350	335	360	480	435	12	25	30	690	500
400	380	395	540	495	16	25	30	770	560

尺寸表 SIZE TABLE (7308)

DN	d	L	D	C	NO.	h	t	H	D2
50	50	120	155	120	4	19	20	255	160
65	65	130	175	140	4	19	22	270	200
80	80	140	185	150	8	19	22	275	200
100	100	160	210	175	8	19	24	315	250
125	125	180	250	210	8	23	24	360	280
150	150	205	280	240	8	23	26	405	315
200	200	230	330	290	12	23	26	475	355
250	250	290	400	355	12	25	30	570	450
300	300	320	445	400	16	25	32	645	500
350	335	360	490	445	16	25	34	710	560
400	380	420	560	510	16	27	36	790	630

尺寸表 SIZE TABLE (7310)

DN	d	L	D	C	NO.	h	t	H	D2
50	50	120	155	120	8	19	20	255	160
65	65	130	175	140	8	19	22	270	200
80	80	150	200	160	8	23	24	295	224
100	100	170	225	185	8	23	26	330	250
125	125	200	270	225	8	25	26	390	315
150	150	225	305	260	12	25	28	435	355
200	200	250	350	305	12	25	30	540	450

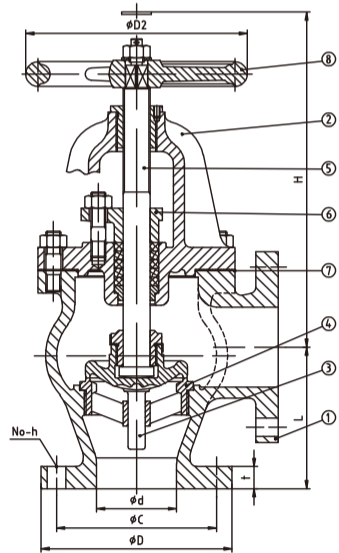

铸铁球形截止止回阀5K F7353 Cast Iron 5K Screw-down Check Globe Valves
 铸铁球形截止止回阀10K F7375 Cast Iron 10K Screw-down Check Globe Valves
 铸铁球形截止止回阀16K F7377 Cast Iron 16K Screw-down Check Globe Valves

材料表 MATERIALS TABLE

序号	零件名称	材料		NAME OF PART	MATERIAL	
		CLASS B	CLASS S		CLASS B	CLASS S
1	阀体	HT200		BODY	FC200	
2	阀盖	HT200		BONNET	FC200	
3	阀盘	ZCuSn5Pb5Zn5	ZG2Cr13	DISC	BC6	SUS 420
4	阀座	ZCuSn5Pb5Zn5	ZG2Cr13	VALVE SEAT	BC6	SUS 420
5	阀杆	HPb59-1	ZG2Cr13	STEM	C377IBD OR BE	SUS 420
6	压盖	ZCuSn5Pb5Zn5		GLAND PACKING	BC6	
7	垫片	非石棉		GASKET	NON-ASBESTOS	
8	手轮	HT200		HANDWHEEL	FC200	

尺寸表 SIZE TABLE (7353)

DN	d	L	D	C	NO.	h	t	H	D2
50	50	210	130	105	4	15	16	270	160
65	65	250	155	130	4	15	18	290	180
80	80	280	180	145	4	19	18	300	180
100	100	340	200	165	8	19	20	350	224
125	125	410	235	200	8	19	20	380	250
150	150	480	265	230	8	19	22	430	280
200	200	570	320	280	8	23	24	505	315
250	250	740	385	345	12	23	26	620	355
300	300	840	430	390	12	23	28	715	400
350	335	940	480	435	12	25	30	815	500
400	380	1050	540	495	16	25	30	905	600

尺寸表 SIZE TABLE (7375)

DN	d	L	D	C	NO.	h	t	H	D2
50	50	220	155	120	4	19	20	285	160
65	65	270	175	140	4	19	22	305	200
80	80	300	185	150	8	19	22	315	200
100	100	350	210	175	8	19	24	360	250
125	125	420	250	210	8	23	24	410	280
150	150	490	280	240	8	23	26	455	315
200	200	570	330	290	12	23	26	530	355
250	250	740	400	355	12	25	30	645	450
300	300	840	445	400	16	25	32	770	500

尺寸表 SIZE TABLE (7377)

DN	d	L	D	C	NO.	h	t	H	D2
50	50	220	155	120	8	19	20	285	160
65	65	270	175	140	8	19	22	305	200
80	80	300	200	160	8	23	24	335	224
100	100	350	225	185	8	23	26	375	250
125	125	430	270	225	8	25	26	440	315
150	150	500	305	260	12	25	28	500	355
200	200	570	350	305	12	25	30	606	450

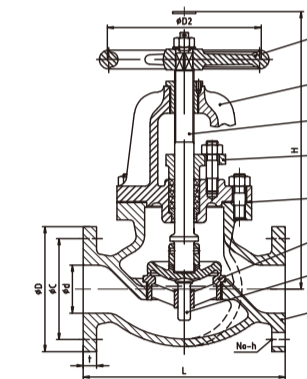

铸铁角式截止止回阀5K F7354 Cast Iron 5K Screw-down Check Angle Valves
 铸铁角式截止止回阀10K F7376 Cast Iron 10K Screw-down Check Angle Valves
 铸铁角式截止止回阀16K F7378 Cast Iron 16K Screw-down Check Angle Valves

材料表 MATERIALS TABLE

序号	零件名称	材料		NAME OF PART	MATERIAL	
		CLASS B	CLASS S		CLASS B	CLASS S
1	阀体	HT200		BODY	FC200	
2	阀盖	HT200		BONNET	FC200	
3	阀盘	ZCuSn5Pb5Zn5	ZG2Cr13	DISC	BC6	SUS 420
4	阀座	ZCuSn5Pb5Zn5	ZG2Cr13	VALVE SEAT	BC6	SUS 420
5	阀杆	HPb59-1	ZG2Cr13	STEM	C377/BD OR BE	SUS 420
6	压盖	ZCuSn5Pb5Zn5		GLAND PACKING	BC6	
7	垫片	非石棉		GASKET	NON-ASBESTOS	
8	手轮	HT200		HANDWHEEL	FC200	

尺寸表 SIZE TABLE (7354)

DN	d	L	D	C	NO.	h	t	H	D2
50	50	100	130	105	4	15	16	240	160
65	65	115	155	130	4	15	18	245	180
80	80	130	180	145	4	19	18	255	180
100	100	150	200	165	8	19	20	300	224
125	125	170	235	200	8	19	20	320	250
150	150	190	265	230	8	19	22	365	280
200	200	220	320	280	8	23	24	425	315
250	250	275	385	345	12	23	26	510	355
300	300	310	430	390	12	23	28	585	400
350	335	360	480	435	12	25	30	660	500
400	380	395	540	495	16	25	30	730	560
450	430	440	605	555	16	25	30	835	630

尺寸表 SIZE TABLE (7376)

DN	d	L	D	C	NO.	h	t	H	D2
50	50	120	155	120	4	19	20	255	160
65	65	130	175	140	4	19	22	260	200
80	80	140	185	150	8	19	22	270	200
100	100	160	210	175	8	19	24	305	250
125	125	180	250	210	8	23	24	350	280
150	150	205	280	240	8	23	26	390	315
200	200	230	330	290	12	23	26	450	355
250	250	290	400	355	12	25	30	536	450
300	300	320	445	400	16	25	32	645	500

尺寸表 SIZE TABLE (7378)

DN	d	L	D	C	NO.	h	t	H	D2
50	50	120	155	120	8	19	20	255	160
65	65	130	175	140	8	19	22	260	200
80	80	150	200	160	8	23	24	290	224
100	100	170	225	185	8	23	26	320	250
125	125	200	270	225	8	25	26	375	315
150	150	225	305	260	12	25	28	425	355
200	200	250	350	305	12	25	30	521	450

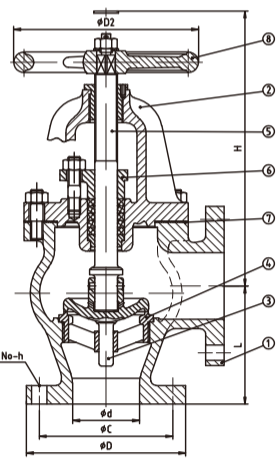

铸铁球形升降式止回阀 F7358 Cast Iron 5K Lift Check Globe Valves
 铸铁角式升降式止回阀 F7359 Cast Iron 5K Lift Check Angle Valves

材料表 MATERIALS TABLE

序号	零件名称	材料		NAME OF PART	MATERIAL	
		CLASS B	CLASS S		CLASS B	CLASS S
1	阀体	HT200		BODY	FC200	
2	阀盖	HT200		BONNET	FC200	
3	阀盘	ZCuSn5Pb5Zn5	ZG2Cr13	DISC	BC6	SUS 420
4	阀座	ZCuSn5Pb5Zn5	ZG2Cr13	VALVE SEAT	BC6	SUS 420
5	垫片	非石棉		GASKET	NON-ASBESTOS	

尺寸表 SIZE TABLE (7358)

DN	d	L	D	C	NO.	h	t	H
50	50	210	130	105	4	15	16	107
65	65	250	155	130	4	15	18	124
80	80	280	180	145	4	19	18	129
100	100	340	200	165	8	19	20	146
125	125	410	235	200	8	19	20	166
150	150	480	265	230	8	19	22	188
200	200	570	320	280	8	23	24	212

尺寸表 SIZE TABLE (7359)

DN	d	L	D	C	NO.	h	t	H
50	50	100	130	105	4	15	16	77
65	65	115	155	130	4	15	18	81
80	80	130	180	145	4	19	18	84
100	100	150	200	165	8	19	20	96
125	125	170	235	200	8	19	20	108
150	150	190	265	230	8	19	22	125
200	200	220	320	280	8	23	24	157
250	250	275	385	345	12	23	26	180

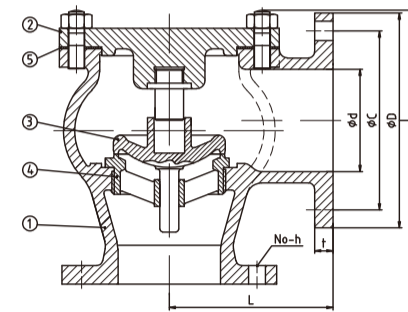
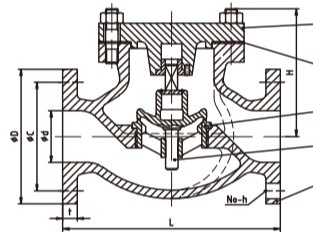

铸铁旋启式止回阀5K F7372 Cast Iron 5K Swing Check Valves
铸铁旋启式止回阀10K F7373 Cast Iron 10K Swing Check Valves

材料表 MATERIALS TABLE

序号	零件名称	材料		NAME OF PART		MATERIAL	
		CLASS B	CLASS S	CLASS B	CLASS S	CLASS B	CLASS S
1	阀体	HT200		BODY		FC200	
2	阀盖	HT200		BONNET		FC200	
3	阀盘	ZCuSn5Pb5Zn5	ZG2Cr13	DISC	BC6	SUS 420	
4	阀座	ZCuSn5Pb5Zn5	ZG2Cr13	VALVE SEAT	BC6	SUS 420	
5	垫片	非石棉		GASKET		NON-ASBESTOS	



尺寸表 SIZE TABLE (7372)

DN	d	L	D	C	NO.	h	t	H
50	50	190	130	105	4	15	16	97
65	65	220	155	130	4	15	18	119
80	80	250	180	145	4	19	18	129
100	100	280	200	165	8	19	20	146
125	125	330	235	200	8	19	20	171
150	150	380	265	230	8	19	22	198
200	200	460	320	280	8	23	24	235
250	250	550	385	345	12	23	26	290
300	300	640	430	390	12	23	28	351

尺寸表 SIZE TABLE (7373)

DN	d	L	D	C	NO.	h	t	H
50	50	210	155	120	4	19	20	109
65	65	240	175	140	4	19	22	126
80	80	270	185	150	8	19	22	136
100	100	300	210	175	8	19	24	153
125	125	350	250	210	8	23	24	180
150	150	400	280	240	8	23	26	205
200	200	480	330	290	12	23	26	242

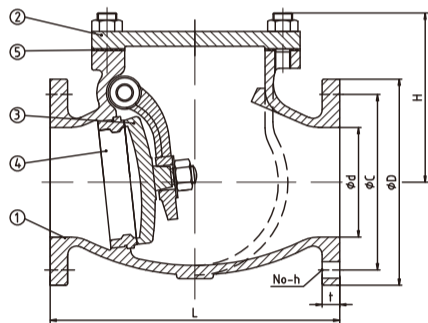

铸铁闸阀5K F7363 Cast Iron 5K Gate Valves
铸铁闸阀10K F7364 Cast Iron 10K Gate Valves
铸铁闸阀16K F7369 Cast Iron 16K Gate Valves

材料表 MATERIALS TABLE

序号	零件名称	材料		NAME OF PART		MATERIAL	
		CLASS B	CLASS S	CLASS B	CLASS S	CLASS B	CLASS S
1	阀体	HT200		BODY		FC200	
2	阀盖	HT200		BONNET		FC200	
3	阀座 (阀体)	ZCuSn5Pb5Zn5	ZG2Cr13	VALVE SEAT	BC6	SUS 420	
4	阀座 (闸板)	ZCuSn5Pb5Zn5	ZG2Cr13	VALVE SEAT	BC6	SUS 420	
5	阀杆	HPb59-1	ZG2Cr13	STEM	C377IBD OR BE	SUS 420	
6	压盖	ZCuSn5Pb5Zn5		GLAND PACKING		BC6	
7	垫片	非石棉		GASKET		NON-ASBESTOS	
8	手轮	HT200		HANDWHEEL		FC200	
9	闸板	HT200		DISC		FC200	



尺寸表 SIZE TABLE (7363)

DN	d	L	D	C	NO.	h	t	H	D2
50	50	180	130	105	4	15	16	285	125
65	65	190	155	130	4	15	18	330	140
80	80	200	180	145	4	19	18	380	160
100	100	230	200	165	8	19	20	430	180
125	125	250	235	200	8	19	20	495	200
150	150	270	265	230	8	19	22	560	224
200	200	290	320	280	8	23	24	680	280
250	250	330	385	345	12	23	26	800	355
300	300	370	430	390	12	23	28	920	400
350	335	410	480	435	12	25	30	1000	450
400	380	470	540	495	16	25	30	1100	500
450	430	500	605	555	16	25	30	1420	560

尺寸表 SIZE TABLE (7364)

DN	d	L	D	C	NO.	h	t	H	D2
50	50	200	155	120	4	19	20	300	140
65	65	220	175	140	4	19	22	350	160
80	80	230	185	150	8	19	22	400	180
100	100	250	210	175	8	19	24	450	200
125	125	270	250	210	8	23	24	520	224
150	150	290	280	240	8	23	26	580	250
200	200	320	330	290	12	23	26	700	315
250	250	380	400	355	12	25	30	840	400
300	300	440	445	400	16	25	32	960	450
350	335	500	490	445	16	25	34	1050	500
400	380	590	560	510	16	27	36	1150	560
450	430	640	620	565	20	27	38	1491	630

尺寸表 SIZE TABLE (7369)

DN	d	L	D	C	NO.	h	t	H	D2
50	50	200	155	120	8	19	20	300	140
65	65	220	175	140	8	19	22	350	160
80	80	230	200	160	8	23	24	400	180
100	100	250	225	185	8	23	26	450	200
125	125	270	270	225	8	25	26	520	224
150	150	290	305	260	12	25	28	580	250
200	200	320	350	305	12	25	30	700	315

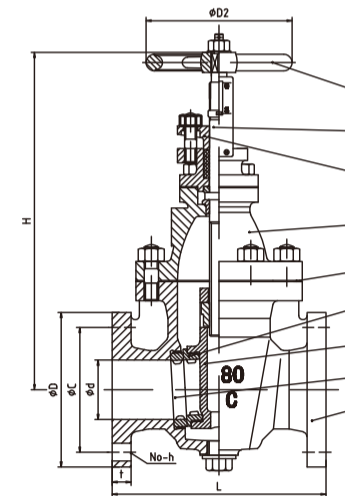

铸铁软管阀门 (球形) F7333 Cast Iron Globe Hose Valves
铸铁软管阀门 (角式) F7333 Cast Iron Angle Hose Valves



材料表 MATERIALS TABLE

序号	零件名称	材料		NAME OF PART	MATERIAL	
		CLASS B	CLASS S		CLASS B	CLASS S
1	阀体	HT200		BODY	FC200	
2	阀盖	HT200		BONNET	FC200	
3	阀盘	ZCuSn5Pb5Zn5	ZG2Cr13	DISC	BC6	SUS 420
4	阀座	ZCuSn5Pb5Zn5	ZG2Cr13	VALVE SEAT	BC6	SUS 420
5	阀杆	HPb59-1	ZG2Cr13	STEM	C3771BD OR BE	SUS 420
6	压盖	ZCuSn5Pb5Zn5		GLAND PACKING	BC6	
7	垫片	非石棉		GASKET	NON-ASBESTOS	
8	手轮	HT200		HANDWHEEL	FC200	

尺寸表 SIZE TABLE (7333)

DN	d	L	D	C	NO.	h	t	H	D2	L1	d1
5K50	50	165	130	105	4	15	16	270	160	105	M64 × 2
10K50	50	170	155	120	4	19	20	285	160	110	M64 × 2
10K65	65	200	175	140	4	19	22	310	200	135	M80 × 2

尺寸表 SIZE TABLE (7333)

DN	d	L	D	C	NO.	h	t	H	D2	L1	d1
5K50	50	155	130	105	4	15	16	240	160	100	M64 × 2
10K50	50	170	155	120	4	19	20	255	160	120	M64 × 2
10K65	65	185	175	140	4	19	22	270	200	130	M80 × 2

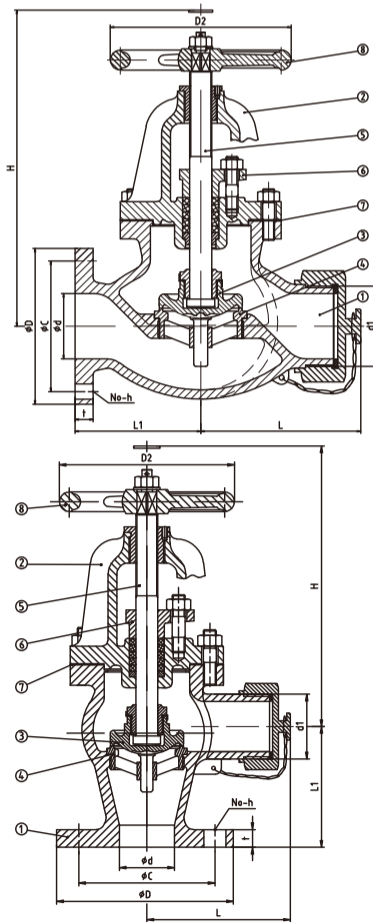

铸铁Y型过滤器 F7220 Cast Iron Y Type Strainer



材料表 MATERIALS TABLE

序号	零件名称	材料	NAME OF PART	MATERIAL
1	阀体	HT200	BODY	FC200
2	阀盖	HT200	BONNET	FC200
3	滤网	1Cr18Ni9Ti	STRAINER	SUS304
4	垫片	非石棉	GASKET	NON-ASBESTOS

尺寸表 SIZE TABLE (7220)

DN	d	L	D	C	NO.	h	t	H
20	20	200	85	65	4	12	14	127
25	25	225	95	75	4	12	14	155
32	32	260	115	90	4	15	16	164
40	40	280	120	95	4	15	16	180
50	50	320	130	105	4	15	16	208
65	65	350	155	130	4	15	18	253
80	80	373	180	145	4	19	18	268
100	100	390	200	165	8	19	20	286
125	125	410	235	200	8	19	20	295
150	150	430	265	230	8	19	20	318

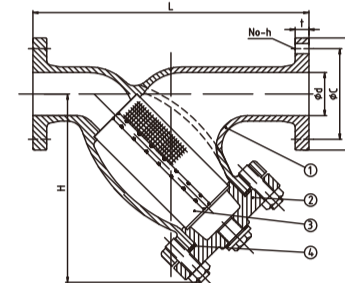

材料表 MATERIALS TABLE

序号	零件名称	材料	NAME OF PART	MATERIAL
1	阀体	HT200	BODY	FC200
2	阀盖	HT200	BONNET	FC200
3	支架	QT500	COVER PUSH	FCD400
4	滤网	Q235A	STRAINER	SS400
5	O型密封圈	丁晴橡胶	O-RING	NBR

尺寸表 SIZE TABLE (7203)

DN	d	L	D	C	NO.	h	t	H
5K50	50	120	130	105	4	15	16	299
5K65	65	150	155	130	4	15	18	341
5K80	80	160	180	145	4	19	18	375
5K100	100	190	200	165	8	19	20	441
10K50	50	120	155	120	4	19	20	299
10K65	65	150	175	140	4	19	22	341
10K80	80	160	185	150	8	19	22	375
10K100	100	190	210	175	8	19	24	441

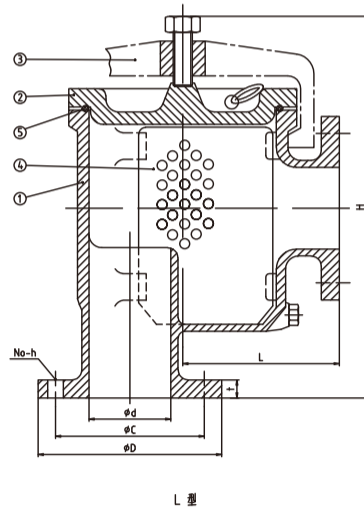

材料表 MATERIALS TABLE

序号	零件名称	材料	NAME OF PART	MATERIAL
1	阀体	HT200	BODY	FC200
2	阀盖	HT200	BONNET	FC200
3	支架	QT500	COVER PUSH	FCD400
4	滤网	1Cr18Ni9Ti	STRAINER	SUS304
5	垫片	丁晴橡胶	GASKET	NBR

尺寸表 SIZE TABLE

S型

DN	d	L	D	C	NO.	h	t	H
25	25	170	95	75	4	12	14	191
32	32	190	115	90	4	15	16	218
40	40	190	120	95	4	15	16	218
50	50	200	130	105	4	15	16	239
65	65	250	155	130	4	15	18	306
80	80	270	180	145	4	19	18	341
100	100	320	200	165	8	19	20	401

L型

DN	d	L	D	C	NO.	h	t	H
25	25	85	95	75	4	12	14	191
32	32	95	115	90	4	15	16	218
40	40	95	120	95	4	15	16	218
50	50	100	130	105	4	15	16	239
65	65	125	155	130	4	15	18	306
80	80	135	180	145	4	19	18	341
100	100	160	200	165	8	19	20	401

尺寸表 SIZE TABLE (7121)

DN	d	L	D	C	NO.	h	t	H	L2
5K125	235	400	200	200	8	19	20	485	30
10K125	250	400	200	210	8	23	24	485	30
5K150	265	460	230	230	8	19	22	575	35
10K150	280	460	230	240	8	23	26	575	35
5K200	320	550	275	280	8	23	24	665	50
10K200	330	550	275	290	12	23	26	665	50

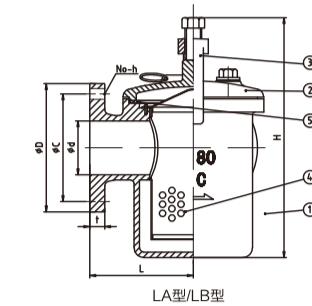
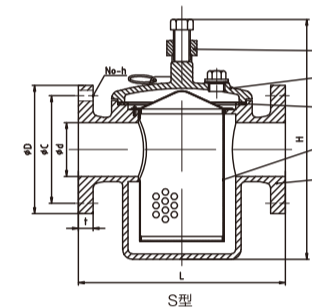
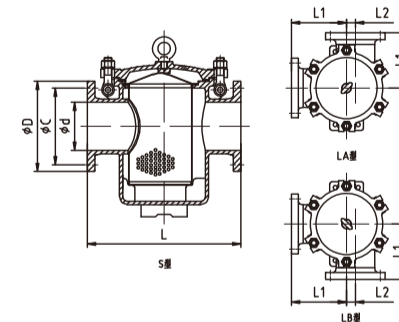

油过滤器 F7209 Shipbuilding-simplex Oil Strainers



材料表 MATERIALS TABLE

序号	零件名称	材料	NAME OF PART	MATERIAL
1	阀体	HT200	BODY	FC200
2	阀盖	HT200	BONNET	FC200
3	支架	QT500	COVER PUSH	FCD400
4	滤网	Q235A	STRAINER	SS400
5	O型密封圈	丁晴橡胶	O-RING	NBR

尺寸表 SIZE TABLE (7209)

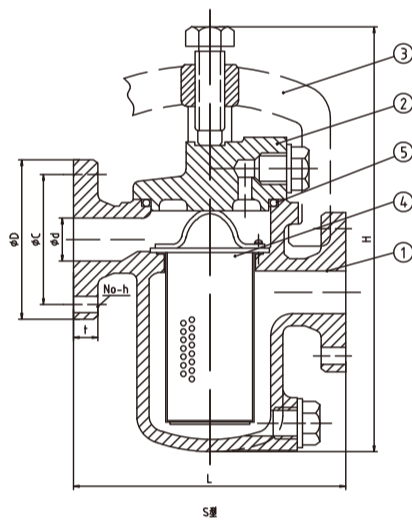

S型

DN	d	L	D	C	NO.	h	t	H
5K20	25	190	85	65	4	12	14	240
5K25	25	190	95	75	4	12	14	240
10K25	25	190	125	90	4	19	18	240
5K32	32	260	115	90	4	15	16	328
10K32	32	260	135	100	4	19	20	328
5K40	40	260	120	95	4	15	16	328
10K40	40	260	140	105	4	19	20	328
5K50	50	280	130	105	4	15	16	405
10K50	50	280	155	120	4	19	20	405
5K65	65	340	155	130	4	15	18	495
10K65	65	340	175	140	4	19	22	495
5K80	80	370	180	145	4	19	18	525
10K80	80	370	185	150	8	19	22	525
5K100	100	420	200	165	8	19	20	651
10K100	100	420	210	175	8	19	24	651

L型

DN	d	L	D	C	NO.	h	t	H
5K25	25	95	95	75	4	12	14	240
10K25	25	95	125	90	4	19	18	240
5K32	32	130	115	90	4	15	16	328
10K32	32	130	135	100	4	19	20	328
5K40	40	130	120	95	4	15	16	328
10K40	40	130	140	105	4	19	20	328
5K50	50	140	130	105	4	15	16	405
10K50	50	140	155	120	4	19	20	405
5K65	65	170	155	130	4	15	18	495
10K65	65	170	175	140	4	19	22	495
5K80	80	185	180	145	4	19	18	525
10K80	80	185	185	150	8	19	22	525
5K100	100	210	200	165	8	19	20	651
10K100	100	210	210	175	8	19	24	651

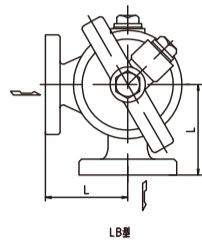
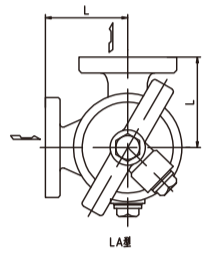

空气管头 Cast Iron Air Vent Head



材料表 MATERIALS TABLE

序号	零件名称	材料	NAME OF PART	MATERIAL
1	阀体	HT200	BODY	FC200
2	浮子	1Cr19Ni9Ti	FLOAT	SUS316
3	密封圈	丁晴橡胶	PACKING	NBR
4	滤网	Q235	STRAINER	SS400

尺寸表 SIZE TABLE

DN	d	D	C	NO.	h	t	H
50	50	130	105	4	15	14	175
65	65	155	130	4	15	14	204
80	80	180	145	4	19	14	244
100	100	200	165	8	19	16	220
125	125	235	200	8	19	16	250
150	150	265	230	8	19	18	285
200	200	320	280	8	23	20	365
250	250	385	345	12	23	22	430
300	300	430	390	12	23	22	530
350	335	480	435	12	25	24	570
400	380	540	495	16	25	24	640
450	430	605	555	16	25	24	713

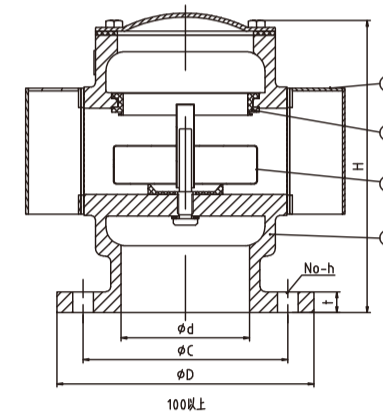
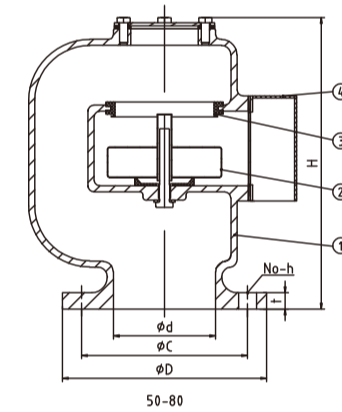

材料表 MATERIALS TABLE

序号	零件名称	材料	NAME OF PART	MATERIAL
		CLASS		CLASS
1	阀体	HT200	BODY	FC200
2	浮子	不锈钢	FLOAT	SS316
3	胶圈	橡胶	RUBBER RING	NBR
4	垫片	非石棉	GASKET	ASBESTOS FREE
5	阀盖	不锈钢	COVER	SS400
6	螺帽	不锈钢	HEX BOLT	SS304
7	护罩	不锈钢	SCREEN COVER	SS304
8	密封垫	橡胶	RUBBER CUSHION	NBR
9	钢平垫	不锈钢	CUSHION	SS304
10	导向柱	不锈钢	GUIDE BOLT	SS304
11	螺帽	不锈钢	HEX BOLT	SS304
12	滤网	不锈钢	FILTER	SS400

尺寸表 SIZE TABLE (53-ON)

DN	d	D	C	NO-h	t	a	H	H1
50	50	130	105	4-15	14	7	184	176
65	65	155	130	4-15	14	7	204	203
80	80	180	145	4-19	14	7	225	238
100	100	200	165	8-19	16	8	265	271
125	125	235	200	8-19	16	8	304	323
150	150	265	230	8-19	18	9	339	378
200	200	320	280	8-23	18	9	434	493

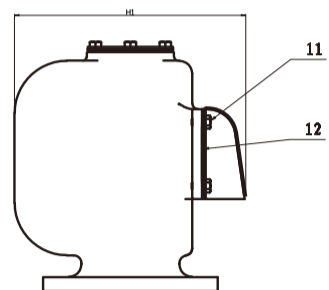
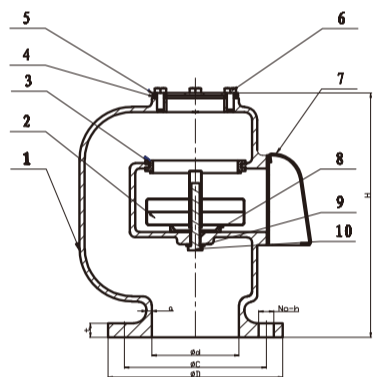

材料表 MATERIALS TABLE

序号	零件名称	材料	NAME OF PART	MATERIAL
1	阀体	ZCuSn5Pb5Zn5	BODY	BC6
2	阀盖	ZCuSn5Pb5Zn5	BONNET	BC6
3	阀盘	ZCuSn5Pb5Zn5	DISC	BC6
4	阀杆	HPb59-1	STEM	C3771BD OR BE
5	垫片	非石棉	GASKET	NON-ASBESTOS
6	手轮	HT200	HANDWHEEL	FC200

尺寸表 SIZE TABLE (7301)

DN	d	L	D	C	NO.	h	t	H	D2
15	15	100	80	60	4	12	9	130	80
20	20	110	85	65	4	12	10	140	100
25	25	120	95	75	4	12	10	160	125
32	32	140	115	90	4	15	12	170	125
40	40	160	120	95	4	15	12	190	140
50	50	210	130	105	4	15	14	235	140
65	65	250	155	130	4	15	14	260	160
80	80	280	180	145	4	19	16	280	160
100	100	340	200	165	8	19	18	333	200

尺寸表 SIZE TABLE (7303)

DN	d	L	D	C	NO.	h	t	H	D2
15	15	110	95	70	4	15	12	130	80
20	20	120	100	75	4	15	14	140	100
25	25	130	125	90	4	19	14	160	125
32	32	160	135	100	4	19	16	170	125
40	40	180	140	105	4	19	16	190	140
50	50	210	155	120	8	19	14	233	140

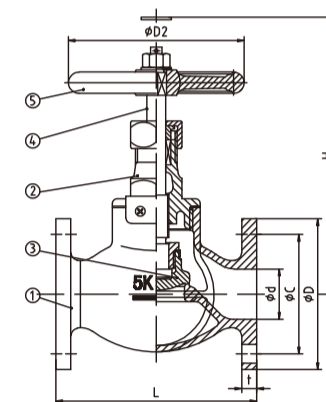

青铜角式截止阀5K F7301 Bronze 5K Angle Valves
青铜角式截止阀16K F7303 Bronze 16K Angle Valves



材料表 MATERIALS TABLE

序号	零件名称	材料	NAME OF PART	MATERIAL
1	阀体	ZCuSn5Pb5Zn5	BODY	BC6
2	阀盖	ZCuSn5Pb5Zn5	BONNET	BC6
3	阀盘	ZCuSn5Pb5Zn5	DISC	BC6
4	阀杆	HPb59-1	STEM	C3771BD OR BE
5	垫片	非石棉	GASKET	NON-ASBESTOS
6	手轮	HT200	HANDWHEEL	FC200

尺寸表 SIZE TABLE (7302)

DN	d	L	D	C	NO.	h	t	H	D2
15	15	55	80	60	4	12	9	120	80
20	20	60	85	65	4	12	10	130	100
25	25	65	95	75	4	12	10	145	125
32	32	80	115	90	4	15	12	150	125
40	40	85	120	95	4	15	12	165	140
50	50	100	130	105	4	15	14	200	140
65	65	115	155	130	4	15	14	220	160

尺寸表 SIZE TABLE (7304)

DN	d	L	D	C	NO.	h	t	H	D2
15	15	70	95	70	4	15	12	120	80
20	20	75	100	75	4	15	14	130	100
25	25	85	125	90	4	19	14	145	125
32	32	95	135	100	4	19	16	150	125
40	40	100	140	105	4	19	16	165	140

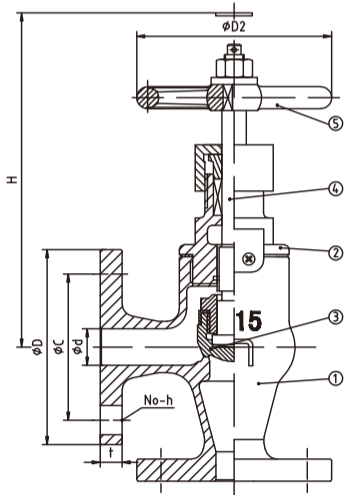

青铜球形截止止回阀5K F7351 Bronze 5K Screw-down Check Globe Valves
青铜球形截止止回阀16K F7409 Bronze 16K Screw-down Check Globe Valves



材料表 MATERIALS TABLE

序号	零件名称	材料	NAME OF PART	MATERIAL
1	阀体	ZCuSn5Pb5Zn5	BODY	BC6
2	阀盖	ZCuSn5Pb5Zn5	BONNET	BC6
3	阀盘	ZCuSn5Pb5Zn5	DISC	BC6
4	阀杆	HPb59-1	STEM	C3771BD OR BE
5	垫片	非石棉	GASKET	NON-ASBESTOS
6	手轮	HT200	HANDWHEEL	FC200

尺寸表 SIZE TABLE (7351)

DN	d	L	D	C	NO.	h	t	H	D2
15	15	100	80	60	4	12	9	130	80
20	20	110	85	65	4	12	10	140	100
25	25	120	95	75	4	12	10	155	125
32	32	140	115	90	4	15	12	165	125
40	40	160	120	95	4	15	12	185	140
50	50	210	130	105	4	15	14	229	140
65	65	250	155	130	4	15	14	250	160
80	80	280	180	145	4	19	16	270	160

尺寸表 SIZE TABLE (7409)

DN	d	L	D	C	NO.	h	t	H	D2
15	15	110	95	70	4	15	12	130	80
20	20	120	100	75	4	15	14	140	100
25	25	130	125	90	4	19	14	155	125
32	32	160	135	100	4	19	16	165	125
40	40	180	140	105	4	19	16	185	140
50	50	210	155	120	8	19	14	229	140

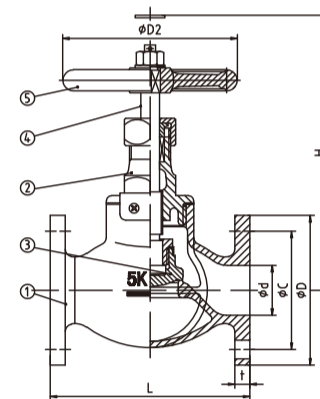

150磅级青铜球形截止阀5K Class 150 Bronze 5K Globe Valves Open/close Indicator
150磅级青铜球形截止阀10K Class 150 Bronze 10K Globe Valves Open/close Indicator

材料表 MATERIALS TABLE

序号	零件名称	材料	NAME OF PART	MATERIAL
1	阀体	ZCuSn5Pb5Zn5	BODY	Bc6
2	阀盖	HPb59-1	BONNET	C3771BD OR BE
3	阀盘	HPb59-1	DISC	C3771BD OR BE
4	阀杆	HPb59-1	STEM	C3771BD OR BE
5	垫片	非石棉	GASKET	NON-ASBESTOS
6	手轮	HT200	HANDWHEEL	FC200

尺寸表 SIZE TABLE (5K)

DN	d	L	D	C	NO.	h	t	H	D2
15	15	60	80	60	4	12	8	77	50
20	20	70	85	65	4	12	9	88	65
25	25	80	95	75	4	12	10	89	65
32	32	100	115	90	4	15	11	110	80
40	40	100	120	95	4	15	12	126	80
50	50	120	130	105	4	15	13	139	100
65	65	140	155	130	4	15	13	154	125
80	80	160	180	145	4	19	16	178	140

尺寸表 SIZE TABLE (10K)

DN	d	L	D	C	NO.	h	t	H	D2
15	15	60	95	70	4	12	8	77	50
20	20	70	100	75	4	15	9	88	65
25	25	80	125	90	4	19	10	89	65
32	32	100	135	100	4	19	11	110	80
40	40	100	140	105	4	19	12	126	80
50	50	120	155	120	4	19	13	139	100
65	65	140	175	140	4	19	13	154	125

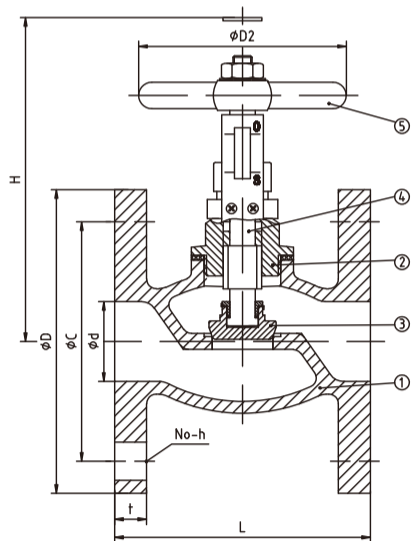

150磅级青铜球形截止回阀5K Class 150 Bronze 5K SDNR Globe Valves Open/close Indicator
150磅级青铜球形截止回阀10K Class 150 Bronze 10K SDNR Globe Valves Open/close Indicator

材料表 MATERIALS TABLE

序号	零件名称	材料	NAME OF PART	MATERIAL
1	阀体	ZCuSn5Pb5Zn5	BODY	Bc6
2	阀盖	HPb59-1	BONNET	C3771BD OR BE
3	阀盘	HPb59-1	DISC	C3771BD OR BE
4	阀杆	HPb59-1	STEM	C3771BD OR BE
5	垫片	非石棉	GASKET	NON-ASBESTOS
6	手轮	HT200	HANDWHEEL	FC200

尺寸表 SIZE TABLE (5K)

DN	d	L	D	C	NO.	h	t	H	D2
15	15	60	80	60	4	12	8	75.5	50
20	20	70	85	65	4	12	9	82.5	65
25	25	80	95	75	4	12	10	88.5	65
32	32	100	115	90	4	15	11	109	80
40	40	100	120	95	4	15	12	121	80
50	50	120	130	105	4	15	13	142	100
65	65	140	155	130	4	15	13	154	125
80	80	160	180	145	4	19	16	175	140

尺寸表 SIZE TABLE (10K)

DN	d	L	D	C	NO.	h	t	H	D2
15	15	60	95	70	4	12	8	75.7	50
20	20	70	100	75	4	15	9	82.5	65
25	25	80	125	90	4	19	10	88.5	65
32	32	100	135	100	4	19	11	110	80
40	40	100	140	105	4	19	12	121	80
50	50	120	155	120	4	19	13	142	100
65	65	140	175	140	4	19	13	154	125

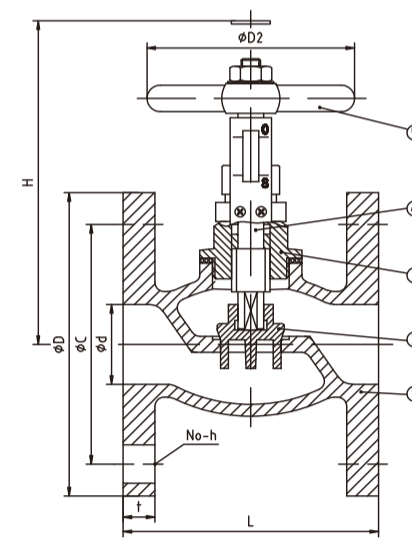

150磅级青铜闸阀5K Class 150 Bronze 5K Gate Valves Open/close Indicator
150磅级青铜闸阀10K Class 150 Bronze 10K Gate Valves Open/close Indicator

材料表 MATERIALS TABLE

序号	零件名称	材料	NAME OF PART	MATERIAL
1	阀体	ZCuSn5Pb5Zn5	BODY	Bc6
2	阀盖	HPb59-1	BONNET	C3771BD OR BE
3	闸板	HPb59-1	DISC	C3771BD OR BE
4	阀杆	HPb59-1	STEM	C3771BD OR BE
5	垫片	非石棉	GASKET	NON-ASBESTOS
6	手轮	HT200	HANDWHEEL	FC200

尺寸表 SIZE TABLE (5K)

DN	d	L	D	C	NO.	h	t	H	D2
15	20	80	80	60	4	12	9	109	80
20	25	80	85	65	4	12	9	110	80
25	25	80	95	75	4	12	9	110	80
32	39	101	115	90	4	15	11	142	100
40	39	101	120	95	4	15	11	142	100
50	50	116	130	105	4	15	12	167	125
65	62	128	155	130	4	15	13	195	125
80	74	144	180	145	4	19	15	218	140
100	100	166	200	165	8	19	15	271	180

尺寸表 SIZE TABLE (10K)

DN	d	L	D	C	NO.	h	t	H	D2
15	20	80	95	70	4	12	9	109	80
20	25	80	100	75	4	15	9	110	80
25	25	80	125	90	4	19	9	110	80
32	39	101	135	100	4	19	11	142	100
40	39	101	140	105	4	19	11	142	100
50	50	116	155	120	4	19	12	167	125
65	62	128	175	140	4	19	13	195	125
80	74	144	185	150	8	19	15	218	140
100	100	166	210	175	8	19	15	271	180

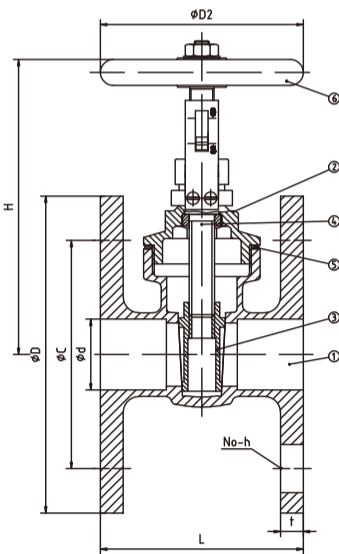

150磅级青铜球阀 Class 150 Flange Bronze Ball Valves

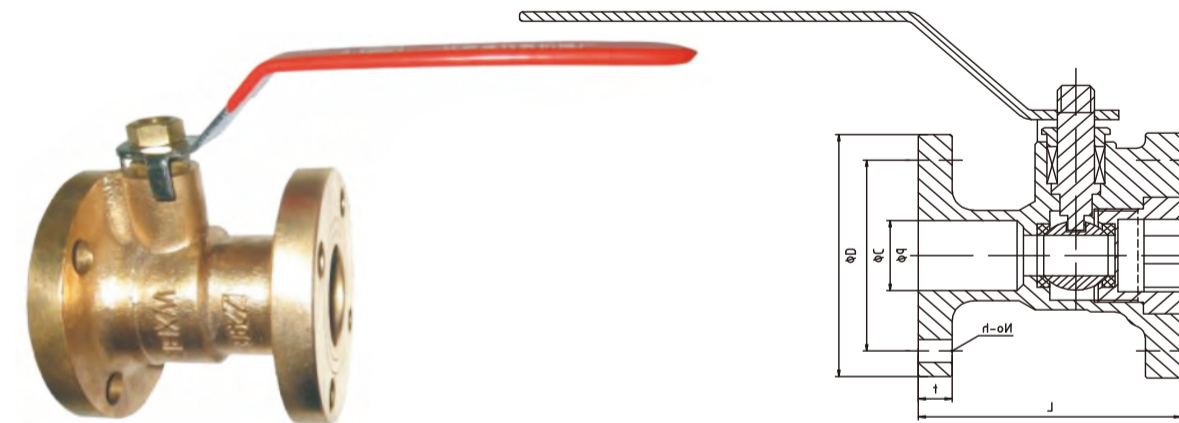

尺寸表 SIZE TABLE

DN	d	L	D	C	n-φh	t
5K15	12.5	76	80	60	4-φ12	11
5K20	15	74	85	65	4-φ12	11.5
5K25	20	78	95	75	4-φ12	11.5
5K32	32	100	115	90	4-φ15	13.5
5K40	32	100	120	95	4-φ15	13.5
10K15	12.5	76	95	70	4-φ15	11
10K20	15	74	100	75	4-φ15	11.5
10K25	20	78	125	90	4-φ19	11.5
10K32	32	100	135	100	4-φ19	13.5
10K40	32	100	140	105	4-φ19	13.5
10K50	40	108	155	120	4-19	16
10K65	50	112	175	140	4-19	18
16K50	40	108	155	120	8-19	16
16K65	50	112	175	140	8-19	18

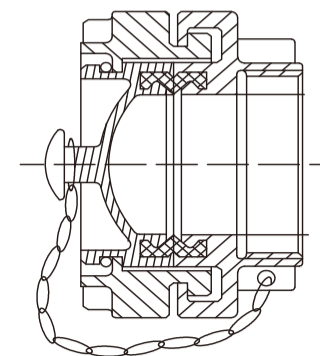

DIN86204
DIN86206
DIN86202
GB2031



青铜闸阀5K F7367 Bronze 5K Rising Stem Type Gate Valves
青铜闸阀10K F7368 Bronze 10K Rising Stem Type Gate Valves



材料表 MATERIALS TABLE

序号	零件名称	材料	NAME OF PART	MATERIAL
1	阀体	ZCuSn5Pb5Zn5	BODY	BC6
2	阀盖	ZCuSn5Pb5Zn5	BONNET	BC6
3	闸板	ZCuSn5Pb5Zn5	DISC	BC6
4	阀杆	HPb59-1	STEM	C3771BD OR BE
5	垫片	非石棉	GASKET	NON-ASBESTOS
6	手轮	HT200	HANDWHEEL	FC200

尺寸表 SIZE TABLE (7367)

DN	d	L	D	C	NO.	h	t	H	D2
15	15	90	80	60	4	12	9	175	80
20	20	100	85	65	4	12	10	200	80
25	25	110	95	75	4	12	10	220	100
32	32	130	115	90	4	15	12	250	100
40	40	140	120	95	4	15	12	290	125
50	50	180	130	105	4	15	16	282	125
65	65	190	155	130	4	15	18	302	140
80	80	200	180	145	4	19	18	335	160
100	100	230	200	165	8	19	18	375	180

尺寸表 SIZE TABLE (7368)

DN	d	L	D	C	NO.	h	t	H	D2
15	15	100	95	70	4	15	12	175	80
20	20	110	100	75	4	15	14	200	80
25	25	120	125	90	4	19	14	220	100
32	32	140	135	100	4	19	16	250	100
40	40	150	140	105	4	19	16	290	125
50	50	200	155	120	4	19	16	282	125
65	65	220	175	140	4	19	18	302	140

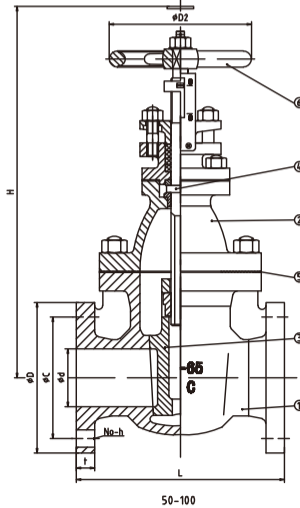
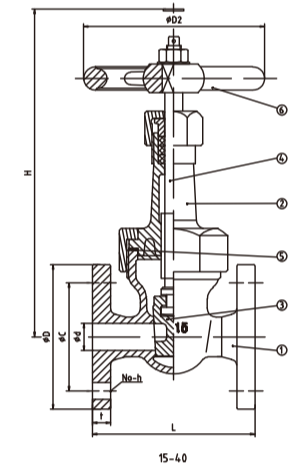

青铜法兰旋塞阀 F7381 Bronze 5K Flanged Cocks Valves



材料表 MATERIALS TABLE

序号	零件名称	材料	NAME OF PART	MATERIAL
1	阀体	ZCuSn5Pb5Zn5	BODY	BC6
2	旋塞	ZCuSn5Pb5Zn5	PLUG	BC6
3	填料压盖	ZCuSn5Pb5Zn5	GLAND PACKING	BC6
4	填料	柔性纸片石墨	PACKING	FLEXIBLE GRAPHITE
5	手柄	KTH300	HANDLE	FCMB30

尺寸表 SIZE TABLE (7381)

DN	d	L	D	C	NO.	h	t	H	I
25	25	130	95	75	4	12	10	105	160
32	32	160	115	90	4	15	12	125	180
40	40	170	120	95	4	15	12	135	190
50	50	190	130	105	4	15	14	163	200
65	65	220	155	130	4	15	14	201	250

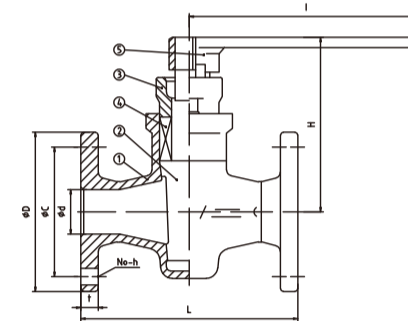

材料表 MATERIALS TABLE

序号	零件名称	材料	NAME OF PART	MATERIAL
1	阀体	ZCuSn5Pb5Zn5	BODY	BC6
2	阀盖	ZCuSn5Pb5Zn5	BONNET	BC6
3	阀盘	ZCuSn5Pb5Zn5	DISC	BC6
4	垫片	非石棉	GASKET	NON-ASBESTOS



尺寸表 SIZE TABLE (7371)

DN	d	L	D	C	NO.	h	t	H
5K15	15	110	80	60	4	12	10	69
5K20	20	110	85	65	4	12	10	69
5K25	25	110	95	75	4	12	10	69
5K32	32	130	115	90	4	15	12	79
5K40	40	140	120	95	4	15	12	93
10K15	15	110	95	70	4	15	10	69
10K20	20	110	100	75	4	15	10	69
10K25	25	110	125	90	4	19	10	69
10K32	32	130	135	100	4	19	12	79
10K40	40	140	140	105	4	19	12	93

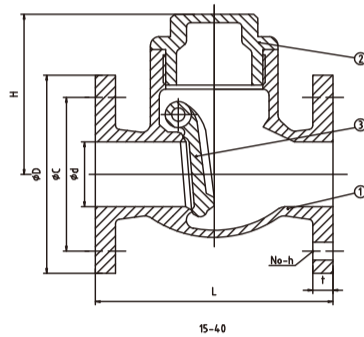

材料表 MATERIALS TABLE

序号	零件名称	材料	NAME OF PART	MATERIAL
1	阀体	ZCuSn5Pb5Zn5	BODY	BC6
2	阀盖	ZCuSn5Pb5Zn5	BONNET	BC6
3	阀盘	ZCuSn5Pb5Zn5	DISC	BC6
4	阀座	ZCuSn5Pb5Zn5	VALVE SEAT	BC6
5	垫片	非石棉	GASKET	NON-ASBESTOS



尺寸表 SIZE TABLE (7371)

DN	d	L	D	C	NO.	h	t	H
5K50	50	190	130	105	4	15	16	97
5K65	65	220	155	130	4	15	18	119
5K80	80	250	180	145	4	19	18	129
10K50	50	210	155	120	4	19	20	109
10K65	65	240	175	140	4	19	22	126
10K80	80	270	185	150	8	19	22	136

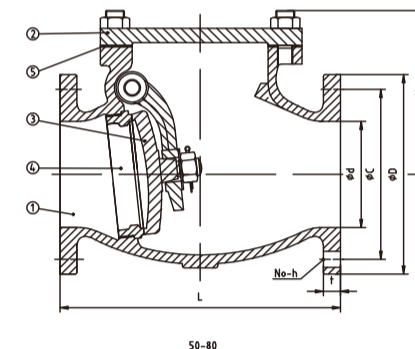

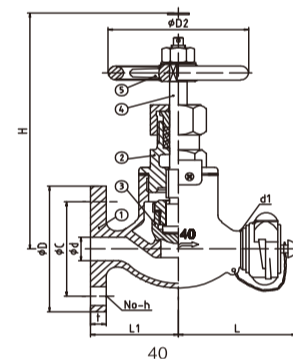
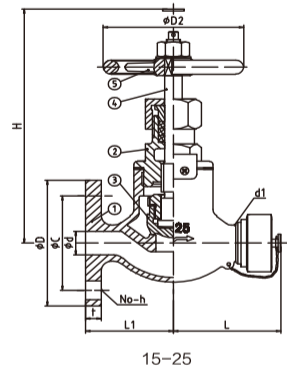

材料表 MATERIALS TABLE (15-40)

序号	零件名称	材料	NAME OF PART	MATERIAL
1	阀体	ZCuSn5Pb5Zn5	BODY	BC6
2	阀盖	ZCuSn5Pb5Zn5	BONNET	BC6
3	阀盘	ZCuSn5Pb5Zn5	DISC	BC6
4	阀杆	HPb59-1	STEM	C3771BD OR BE
5	垫片	非石棉	GASKET	NON-ASBESTOS
6	手轮	HT200	HANDWHEEL	FC200

尺寸表 SIZE TABLE (15-40)

DN	d	L	D	C	NO.	h	t	H	D2	L1	d1
5K15	15	73	80	60	4	12	9	130	80	50	M42×2
10K15	15	73	95	70	4	15	12	130	80	55	M42×2
5K25	25	78	95	75	4	12	10	160	125	60	M42×2
10K25	25	83	125	90	4	19	14	160	125	65	M42×2
5K40	40	129	120	95	4	15	12	190	140	80	M52×2
10K40	40	134	140	105	4	19	16	190	140	90	M52×2

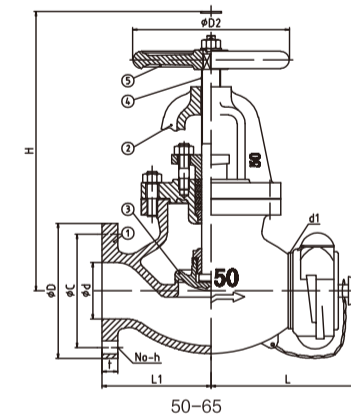

材料表 MATERIALS TABLE (50-65)

序号	零件名称	材料	NAME OF PART	MATERIAL
1	阀体	ZCuSn5Pb5Zn5	BODY	BC6
2	阀盖	ZCuSn5Pb5Zn5	BONNET	BC6
3	阀盘	ZCuSn5Pb5Zn5	DISC	BC6
4	阀杆	HPb59-1	STEM	C3771BD OR BE
5	压盖	ZCuSn5Pb5Zn5	GLAND PACKING	BC6
6	垫片	非石棉	GASKET	NON-ASBESTOS
7	手轮	HT200	HANDWHEEL	FC200

尺寸表 SIZE TABLE (50-65)

DN	d	L	D	C	NO.	h	t	H	D2	L1	d1
5K50	50	160	130	105	4	15	14	270	160	105	M64×2
10K50	50	165	155	120	4	19	16	285	160	110	M64×2
10K65	65	200	175	140	4	19	18	310	200	135	M80×2

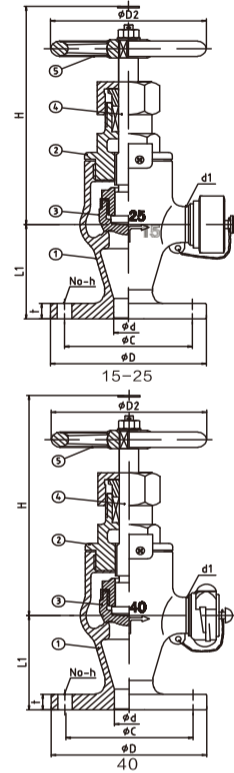

材料表 MATERIALS TABLE (15-40)

序号	零件名称	材料	NAME OF PART	MATERIAL
1	阀体	ZCuSn5Pb5Zn5	BODY	BC6
2	阀盖	ZCuSn5Pb5Zn5	BONNET	BC6
3	阀盘	ZCuSn5Pb5Zn5	DISC	BC6
4	阀杆	HPb59-1	STEM	C3771BD OR BE
5	垫片	非石棉	GASKET	NON-ASBESTOS
6	手轮	HT200	HANDWHEEL	FC200

尺寸表 SIZE TABLE (15-40)

DN	d	L	D	C	NO.	h	t	H	D2	L1	d1
5K15	15	68	80	60	4	12	9	120	80	55	M42 × 2
10K15	15	73	95	70	4	15	12	120	80	70	M42 × 2
5K25	25	78	95	75	4	12	10	145	125	65	M42 × 2
10K25	25	83	125	90	4	19	14	145	125	85	M42 × 2
5K40	40	124	120	95	4	15	12	165	140	85	M52 × 2
10K40	40	124	140	105	4	19	16	165	140	100	M52 × 2

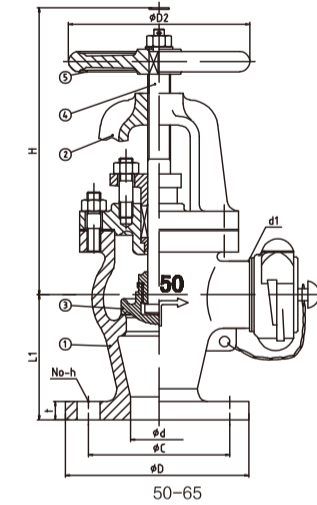

材料表 MATERIALS TABLE (50-65)

序号	零件名称	材料	NAME OF PART	MATERIAL
1	阀体	ZCuSn5Pb5Zn5	BODY	BC6
2	阀盖	ZCuSn5Pb5Zn5	BONNET	BC6
3	阀盘	ZCuSn5Pb5Zn5	DISC	BC6
4	阀杆	HPb59-1	STEM	C3771BD OR BE
5	压盖	ZCuSn5Pb5Zn5	GLAND PACKING	BC6
6	垫片	非石棉	GASKET	NON-ASBESTOS
7	手轮	HT200	HANDWHEEL	FC200

尺寸表 SIZE TABLE (50-65)

DN	d	L	D	C	NO.	h	t	H	D2	L1	d1
5K50	50	155	130	105	4	15	14	240	160	100	M64 × 2
10K50	50	160	155	120	4	19	16	255	160	120	M64 × 2
10K65	65	180	175	140	4	19	18	270	200	130	M80 × 2

青铜Y型过滤器 F7220Q Bronze Y Type Strainer

材料表 MATERIALS TABLE

序号	零件名称	材料	NAME OF PART	MATERIAL
1	阀体	ZCuSn5Pb5Zn5	BODY	BC6
2	阀盖	ZCuSn5Pb5Zn5	BONNET	BC6
3	滤网	1Cr18Ni9Ti	STRAINER	SUS304
4	垫片	非石棉	GASKET	NON-ASBESTOS

尺寸表 SIZE TABLE (7220Q)

DN	d	L	D	C	NO.	h	t	H
5K15	25	165	80	60	4	12	9	86
5K20	25	165	85	65	4	12	10	86
5K25	25	165	95	75	4	12	10	86
5K32	40	170	115	90	4	15	12	106
5K40	40	170	120	95	4	15	12	106
5K80	80	373	180	145	4	19	18	266

尺寸表 SIZE TABLE (7220Q)

DN	d	L	D	C	NO.	h	t	H
10K/16K15	25	165	95	70	4	12	12	86
10K/16K20	25	165	100	75	4	15	14	86
10K/16K25	25	165	125	90	4	19	14	86
10K/16K32	40	170	135	100	4	19	16	106
10K/16K40	40	170	140	105	4	19	16	106

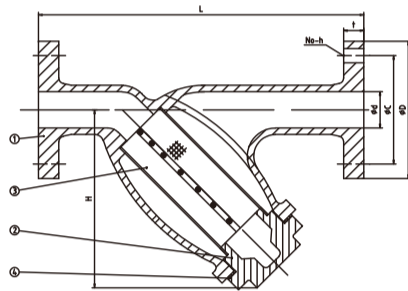

自闭闸阀式短测深管头 F3019 Self-closing Gate Valve Heads For Sounding Pipe

材料表 MATERIALS TABLE

序号	零件名称	材料	NAME OF PART	MATERIAL
1	阀体	ZCuSn5Pb5Zn5	BODY	BC6
2	阀盖	ZCuSn5Pb5Zn5	BONNET	BC6
3	闸板	ZCuSn5Pb5Zn5	DISC	BC6
4	阀杆	HPb59-1	STEM	C3771BD OR BE
5	垫片	非石棉	GASKET	NON-ASBESTOS
6	手轮	ZCuSn5Pb5Zn5	HANDWHEEL	BC6

尺寸表 SIZE TABLE

DN	d	d4	H1	L
40	G1 1/2	G1 1/2	54	160
50	G2	G2	60	160

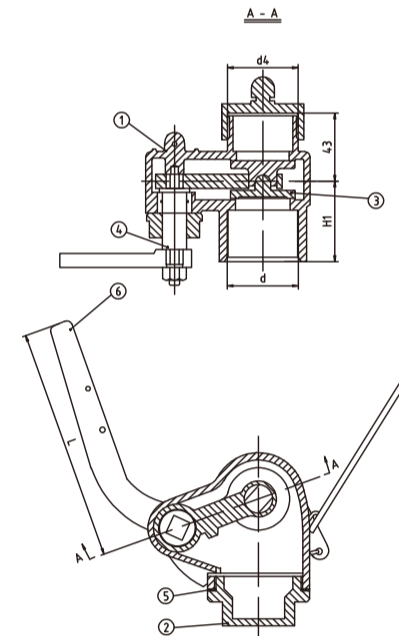

自闭式放卸阀 F7398 Shipbuilding-fuel Oil Tank Self-closing Drain Valves U/F Type



材料表 MATERIALS TABLE

序号	零件名称	材料	NAME OF PART	MATERIAL
1	阀体	ZCuSn5Pb5Zn5	BODY	BC6
2	阀盖	ZCuSn5Pb5Zn5	BONNET	BC6
3	阀盘	ZCuSn5Pb5Zn5	DISC	BC6
4	阀杆	HPb59-1	STEM	C3771BD OR BE
5	手柄	Q235A	HANDLE	SS400

尺寸表 SIZE TABLE (7398U型/MODEL)

DN	d	L	D	C	NO.	h	T	H	L1
5K15U	15	55	80	60	4	12	9	179	55
10K15U	15	55	95	70	4	15	12	179	55
5K20U	20	65	85	65	4	12	10	187	65
10K20U	20	65	100	75	4	15	14	187	65
5K25U	25	65	95	75	4	12	10	187	65
10K25U	25	65	125	90	4	19	14	187	65
5K40U	40	90	120	95	4	15	12	229	100
5K65U	65	135	155	130	4	15	14	252	160

尺寸表 SIZE TABLE (7398F型/MODEL)

DN	d	L	D	C	NO.	h	t	H
5K15F	15	110	80	60	4	12	9	179
5K20F	20	130	85	65	4	12	10	187
10K20F	20	130	100	75	4	15	14	187
5K40F	40	180	120	95	4	15	12	229

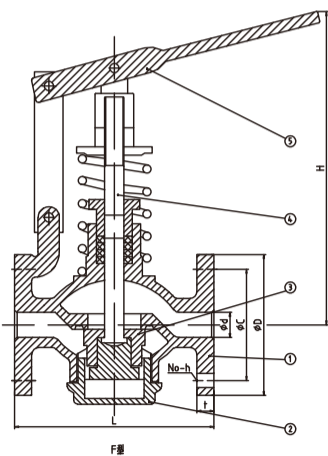
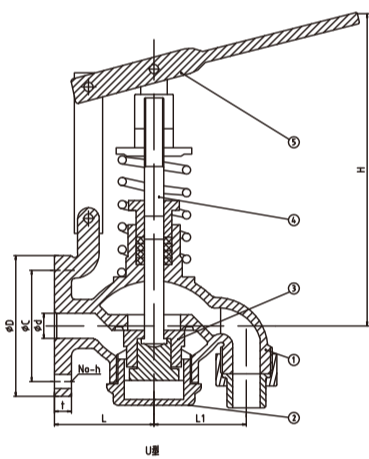

快速切断阀 F7399 Fuel Oil Tank Emergency Shut-off Valves



材料表 MATERIALS TABLE

序号	零件名称	材料	NAME OF PART	MATERIAL
1	阀体	ZCuSn5Pb5Zn5	BODY	BC6
2	阀盖	ZCuSn5Pb5Zn5	BONNET	BC6
3	阀盘	ZCuSn5Pb5Zn5	DISC	BC6
4	阀座	ZCuSn5Pb5Zn5	VALVE SEAT	BC6
5	阀杆	HPb59-1	STEM	C3771BD OR BE
6	操作杆	1Cr13	OPERATING SPINDLE	SUS403
7	垫片	非石棉	GASKET	NON-ASBESTOS
8	手轮	HT200	HANDWHEEL	FC200
9	气动头			

尺寸表 SIZE TABLE (7399)

DN	d	L	D	C	NO.	h	t	H	D2
5K15	15	120	80	60	4	12	9	268	120
5K20	20	120	85	65	4	12	10	268	120
5K25	25	120	95	75	4	12	10	268	120
5K40	40	160	120	95	4	15	12	302	140
5K50	50	210	130	105	4	15	14	316	140
5K65	65	250	155	130	4	15	14	391	180
5K80	80	280	180	145	4	19	18	416	180
10K15	15	130	95	70	4	15	12	268	120
10K20	20	130	100	75	4	15	14	268	120
10K25	25	130	125	90	4	19	14	268	120
10K40	40	170	140	105	4	19	16	302	140
10K50	50	220	155	120	4	19	16	316	140
10K65	65	270	175	140	4	19	18	391	180
10K80	80	300	185	150	8	19	18	416	180

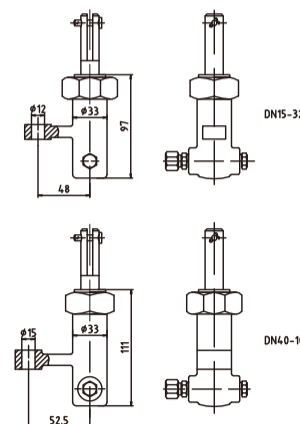
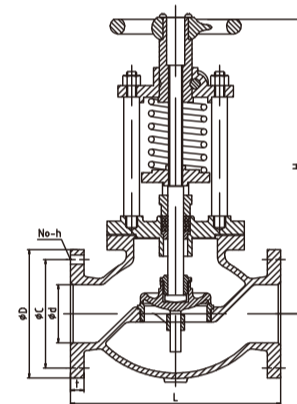

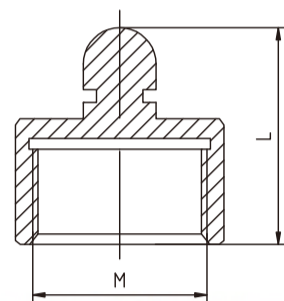
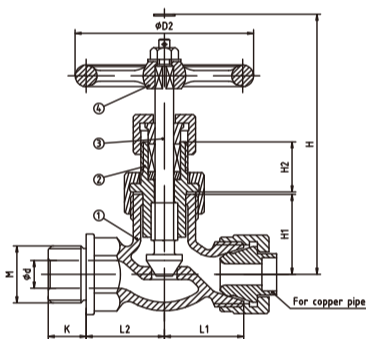

材料表 MATERIALS TABLE

序号	零件名称	材料	NAME OF PART	MATERIAL
1	阀体	ZCuSn5Pb5Zn5	BODY	BC6
2	阀盖	ZCuSn5Pb5Zn5	BONNET	BC6
3	阀杆	HPb59-1	STEM	C3771BD OR BE
4	手轮	HT200	HANDWHEEL	FC200

尺寸表 SIZE TABLE(S Type)

DN	COPPER PIPE	K	L2	L1	H1	H2	H	M	D2
6	φ10	12	32	32	30	22	100	M20×1.5	65
10	φ15	16	35	36	33	29	115	M24×2	80

尺寸表 SIZE TABLE(U Type)

DN	COPPER PIPE	K	L2	L1	H1	H2	H	M	D2
6	φ10	12	32	32	30	22	100	—	65
10	φ15	16	35	36	33	29	115	—	80

Brass Bonnet Measurement

黄铜测量头盖

材料表 MATERIALS TABLE

序号	零件名称	材料	NAME OF PART	MATERIAL
1	阀体	ZCuZn40Pb2	BODY	ZCuZn40Pb2

尺寸表 SIZE TABLE

DN	d	L
32	G1 1/4	50
40	G1 1/2	50
50	G2	50
65	G2 1/2	56
80	G3	56

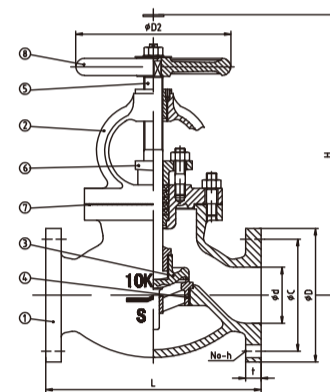

材料表 MATERIALS TABLE

序号	零件名称	材料		NAME OF PART	MATERIAL	
		CLASS B	CLASS S		CLASS B	CLASS S
1	阀体	ZG230-460		BODY	SC450	
2	阀盖	ZG230-460		BONNET	SC450	
3	阀盘	ZCuSn5Pb5Zn5	ZG2Cr13	DISC	BC6	SUS420
4	阀座	ZCuSn5Pb5Zn5	ZG2Cr13	VALVE SEAT	BC6	SUS420
5	阀杆	HPb59-1	ZG2Cr13	STEM	C3771BD OR BE	SUS 420
6	压盖	ZCuSn5Pb5Zn5		GLAND PACKING	BC6	
7	垫片	非石棉		GASKET	NON-ASBESTOS	
8	手轮	HT200		HANDWHEEL	FC200	

尺寸表 SIZE TABLE(7311)

DN	d	L	D	C	NO.	h	t	H	D2
50	50	210	130	105	4	15	14	270	160
65	65	250	155	130	4	15	14	300	180
80	80	280	180	145	4	19	16	310	180
100	100	340	200	165	8	19	16	360	224
125	125	410	235	200	8	19	16	390	250
150	150	480	265	230	8	19	18	445	280
200	200	570	320	280	8	23	20	530	315
250	250	740	385	345	12	23	22	650	355
300	300	840	430	390	12	23	24	740	400

尺寸表 SIZE TABLE(7319)

DN	d	L	D	C	NO.	h	t	H	D2
50	50	220	155	120	4	19	16	270	160
65	65	270	175	140	4	19	18	300	200
80	80	300	185	150	8	19	18	310	200
100	100	350	210	175	8	19	18	355	250
125	125	420	250	210	8	23	20	415	280
150	150	490	280	240	8	23	22	470	315
200	200	570	330	290	12	23	22	565	355
250	250	740	400	355	12	25	24	645	400
300	300	840	445	400	16	25	24	735	450

尺寸表 SIZE TABLE(7313)

DN	d	L	D	C	NO.	h	t	H	D2
32	32	190	135	100	4	19	18	270	160
40	40	200	140	105	4	19	18	290	160
50	50	230	155	120	8	19	18	305	200
65	65	270	175	140	8	19	20	345	224
80	80	300	200	160	8	23	22	385	250
100	100	350	225	185	8	23	24	440	280
125	125	430	270	225	8	25	26	500	315
150	150	500	305	260	12	25	28	550	355
200	200	560	350	305	12	25	30	630	450
250	250	660	430	380	12	27	34	725	560



ΦJPLS valves

铸钢球形截止止回阀5K F7311C Cast Steel 5K Screw-down Check Globe Valves
 铸钢球形截止止回阀10K F7471 Cast Steel 10K Screw-down Check Globe Valves
 铸钢球形截止止回阀20K F7473 Cast Steel 20K Screw-down Check Globe Valves

材料表 MATERIALS TABLE

序号	零件名称	材料		NAME OF PART	MATERIAL	
		CLASS B	CLASS S		CLASS B	CLASS S
1	阀体	ZG230-460		BODY	SC450	
2	阀盖	ZG230-460		BONNET	SC450	
3	阀盘	ZCuSn5Pb5Zn5	ZG2Cr13	DISC	BC6	SUS 420
4	阀座	ZCuSn5Pb5Zn5	ZG2Cr13	VALVE SEAT	BC6	SUS 420
5	阀杆	HPb59-1	ZG2Cr13	STEM	C3771BD OR BE	SUS 420
6	压盖	ZCuSn5Pb5Zn5		GLAND PACKING	BC6	
7	垫片	非石棉		GASKET	NON-ASBESTOS	
8	手轮	HT200		HANDWHEEL	FC200	

尺寸表 SIZE TABLE (7311C)

DN	d	L	D	C	NO.	h	t	H	D2
50	50	210	130	105	4	15	14	270	160
65	65	250	155	130	4	15	14	290	180
80	80	280	180	145	4	19	16	300	180
100	100	340	200	165	8	19	16	350	224
125	125	410	235	200	8	19	16	380	250
150	150	480	265	230	8	19	18	430	280
200	200	570	320	280	8	23	20	505	315
250	250	740	385	345	12	23	22	620	355
300	300	840	430	390	12	23	24	715	400

尺寸表 SIZE TABLE (7471)

DN	d	L	D	C	NO.	h	t	H	D2
50	50	220	155	120	4	19	16	265	160
65	65	270	175	140	4	19	18	295	200
80	80	300	185	150	8	19	18	300	200
100	100	350	210	175	8	19	18	345	250
125	125	420	250	210	8	23	20	405	280
150	150	490	280	240	8	23	22	455	315
200	200	570	330	290	12	23	22	545	355
250	250	740	400	355	12	25	24	645	400
300	300	840	445	400	16	25	24	735	450

尺寸表 SIZE TABLE (7473)

DN	d	L	D	C	NO.	h	t	H	D2
32	32	190	135	100	4	19	18	265	160
40	40	200	140	105	4	19	18	280	160
50	50	230	155	120	8	19	18	295	200
65	65	270	175	140	8	19	20	330	224
80	80	300	200	160	8	23	22	370	250
100	100	350	225	185	8	23	24	420	280
125	125	430	270	225	8	25	26	475	315
150	150	500	305	260	12	25	28	525	355
200	200	560	350	305	12	25	30	605	450
250	250	660	430	380	12	27	34	700	560

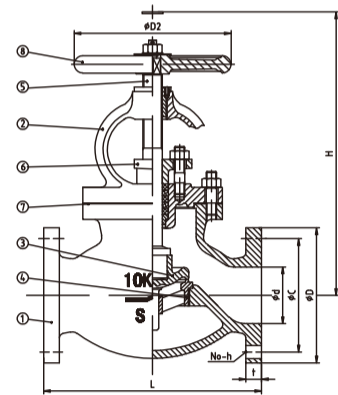

ΦJPLS valves

铸钢角式截止阀5K F7312 Cast Steel 5K Angle Valves
 铸钢角式截止阀10K F7320 Cast Steel 10K Angle Valves
 铸钢角式截止阀20K F7314 Cast Steel 20K Angle Valves

材料表 MATERIALS TABLE

序号	零件名称	材料		NAME OF PART	MATERIAL	
		CLASS B	CLASS S		CLASS B	CLASS S
1	阀体	ZG230-460		BODY	SC450	
2	阀盖	ZG230-460		BONNET	SC450	
3	阀盘	ZCuSn5Pb5Zn5	ZG2Cr13	DISC	BC6	SUS 420
4	阀座	ZCuSn5Pb5Zn5	ZG2Cr13	VALVE SEAT	BC6	SUS 420
5	阀杆	HPb59-1	ZG2Cr13	STEM	C3771BD OR BE	SUS 420
6	压盖	ZCuSn5Pb5Zn5		GLAND PACKING	BC6	
7	垫片	非石棉		GASKET	NON-ASBESTOS	
8	手轮	HT200		HANDWHEEL	FC200	

尺寸表 SIZE TABLE (7312)

DN	d	L	D	C	NO.	h	t	H	D2
50	50	100	130	105	4	15	14	240	160
65	65	115	155	130	4	15	14	255	180
80	80	130	180	145	4	19	16	265	180
100	100	150	200	165	8	19	16	310	224
125	125	170	235	200	8	19	16	330	250
150	150	190	265	230	8	19	18	380	280
200	200	220	320	280	8	23	20	450	315
250	250	275	385	345	12	23	22	540	355
300	300	310	430	390	12	23	22	610	400

尺寸表 SIZE TABLE (7320)

DN	d	L	D	C	NO.	h	t	H	D2
50	50	120	155	120	4	19	16	240	160
65	65	130	175	140	4	19	18	260	200
80	80	140	185	150	8	19	18	265	200
100	100	160	210	175	8	19	18	300	250
125	125	180	250	210	8	23	20	350	280
150	150	205	280	240	8	23	22	400	315
200	200	230	330	290	12	23	22	485	355
250	250	290	400	355	12	25	24	535	400
300	300	320	445	400	16	25	24	610	450

尺寸表 SIZE TABLE (7314)

DN	d	L	D	C	NO.	h	t	H	D2
32	32	100	135	100	4	19	18	270	160
40	40	110	140	105	4	19	18	290	160
50	50	125	155	120	8	19	18	305	200
65	65	135	175	140	8	19	20	345	224
80	80	150	200	160	8	23	22	385	250
100	100	170	225	185	8	23	24	440	280
125	125	200	270	225	8	25	26	500	315
150	150	225	305	260	12	25	28	550	355
200	200	280	350	305	12	25	30	630	450
250	250	310	430	380	12	27	34	725	560

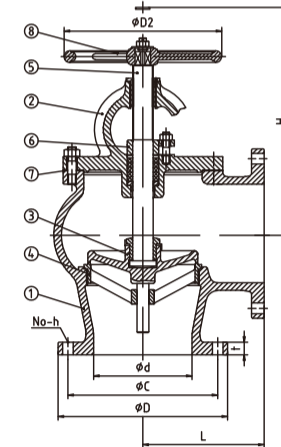

铸钢角式截止止回阀5K F7312C Cast Steel 5K Screw-down Check Angle Valves
铸钢角式截止止回阀10K F7472 Cast Steel 10K Screw-down Check Angle Valves
铸钢角式截止止回阀20K F7474 Cast Steel 20K Screw-down Check Angle Valves

材料表 MATERIALS TABLE

序号	零件名称	材料		NAME OF PART	MATERIAL	
		CLASS B	CLASS S		CLASS B	CLASS S
1	阀体	ZG230-460		BODY	SC450	
2	阀盖	ZG230-460		BONNET	SC450	
3	阀盘	ZCuSn5Pb5Zn5	ZG2Cr13	DISC	BC6	SUS 420
4	阀座	ZCuSn5Pb5Zn5	ZG2Cr13	VALVE SEAT	BC6	SUS 420
5	阀杆	HPb59-1	ZG2Cr13	STEM	C377IBD OR BE	SUS 420
6	压盖	ZCuSn5Pb5Zn5		GLAND PACKING	BC6	
7	垫片	非石棉		GASKET	NON-ASBESTOS	
8	手轮	HT200		HANDWHEEL	FC200	

尺寸表 SIZE TABLE (7312C)

DN	d	L	D	C	NO.	h	t	H	D2
50	50	100	130	105	4	15	14	240	160
65	65	115	155	130	4	15	14	245	180
80	80	130	180	145	4	19	16	255	180
100	100	150	200	165	8	19	16	300	224
125	125	170	235	200	8	19	16	320	250
150	150	190	265	230	8	19	18	365	280
200	200	220	320	280	8	23	20	425	315
250	250	275	385	345	12	23	22	510	355
300	300	310	430	390	12	23	22	585	400

尺寸表 SIZE TABLE (7472)

DN	d	L	D	C	NO.	h	t	H	D2
50	50	120	155	120	4	19	16	235	160
65	65	130	175	140	4	19	18	250	200
80	80	140	185	150	8	19	18	255	200
100	100	160	210	175	8	19	18	290	250
125	125	180	250	210	8	23	20	340	280
150	150	205	280	240	8	23	22	385	315
200	200	230	330	290	12	23	22	460	355
250	250	290	400	355	12	25	24	535	400
300	300	320	445	400	16	25	24	610	450

尺寸表 SIZE TABLE (7474)

DN	d	L	D	C	NO.	h	t	H	D2
32	32	100	135	100	4	19	18	270	160
40	40	110	140	105	4	19	18	290	160
50	50	125	155	120	8	19	18	305	200
65	65	135	175	140	8	19	20	345	224
80	80	150	200	160	8	23	22	385	250
100	100	170	225	185	8	23	24	440	280
125	125	200	270	225	8	25	26	500	315
150	150	225	305	260	12	25	28	550	355
200	200	280	350	305	12	25	30	630	450
250	250	310	430	380	12	27	34	725	560

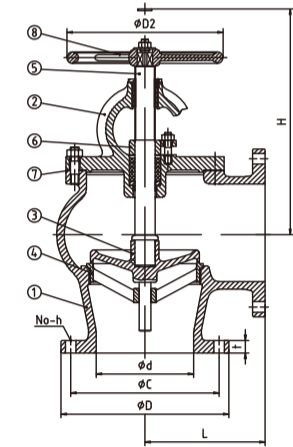

铸钢截止阀40K F7317 marine cast steel 40K globe valve
铸钢截止阀40K F7318 marine cast steel 40K globe valve

材料表 MATERIALS TABLE

序号	零件名称	材料		NAME OF PART	MATERIAL	
		CLASS S			CLASS S	
1	阀体	ZG230-450		BODY	SC450	
2	阀盖	ZG230-450		BONNET	SC450	
3	上阀口	ZG2CR13		DISC	SUS420	
4	焊接密封圈	焊接304		WELDING SEALING RING	SUS304	
5	丝杆	ZG2CR13		STEM	SUS420	
6	填料压盖	ZG2CR13		GLAND PACKING	BC6	
7	垫片	非石棉		GASKET	NON-ASBESTOS	
8	手轮	HT200		HANDWHEEL	FC200	
9						

尺寸表 SIZE TABLE (7317)

DN	d	L	D	C	NO.	h	t	H	D1
32	32	229	140	105	4	19	24	370	200
40	40	241	160	120	4	23	24	395	200
50	50	292	165	130	8	19	26	435	224
65	65	330	200	160	8	23	30	490	250
80	80	356	210	170	8	23	32	540	315
100	100	432	250	205	8	25	36	640	400
125	125	508	300	250	8	27	40	720	450
150	150	559	355	295	12	33	44	815	500

尺寸表 SIZE TABLE (7318)

DN	d	L	D	C	NO.	h	t	H	D1
32	32	114	140	105	4	19	24	350	200
40	40	121	160	120	4	23	24	370	200
50	50	146	165	130	8	19	26	405	224
65	65	165	200	160	8	23	30	455	250
80	80	178	210	170	8	23	32	500	315
100	100	216	250	205	8	25	36	590	400
125	125	254	300	250	8	27	40	660	450
150	150	279	355	295	12	33	44	740	500

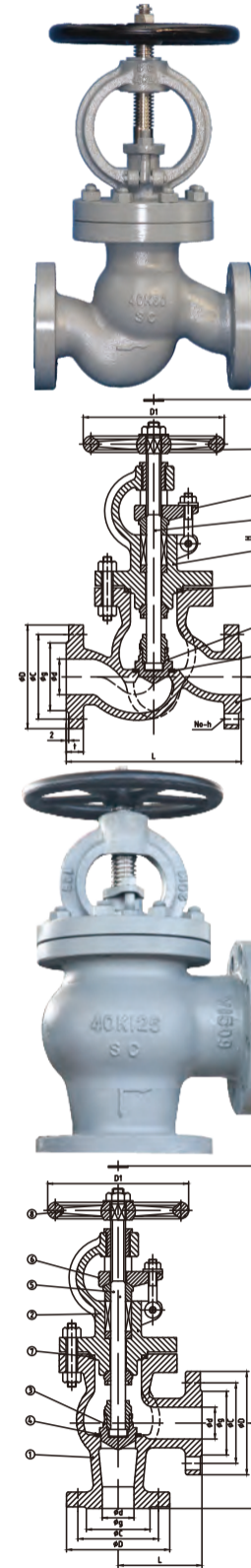

铸钢闸阀5K F7363C Cast Steel 5K Gate Valves
铸钢闸阀10K F7366 Cast Steel 10K Gate Valves

材料表 MATERIALS TABLE

序号	零件名称	材料		NAME OF PART	MATERIAL	
		CLASS B	CLASS S		CLASS B	CLASS S
1	阀体	ZG230-460		BODY	SC450	
2	阀盖	ZG230-460		BONNET	SC450	
3	阀座 (阀体)	ZCuSn5Pb5Zn5	ZG2Cr13	VALVE SEAT	BC6	SUS 420
4	阀座 (闸板)	ZCuSn5Pb5Zn5	ZG2Cr13	VALVE SEAT	BC6	SUS 420
5	阀杆	HPb59-1	ZG2Cr13	STEM	C3771BD OR BE	SUS 420
6	压盖	ZCuSn5Pb5Zn5		GLAND PACKING	BC6	
7	垫片	非石棉		GASKET	NON-ASBESTOS	
8	手轮	HT200		HANDWHEEL	FC200	
9	闸板	ZG230-460		DISC	SC450	

尺寸表 SIZE TABLE (7363C)

DN	d	L	D	C	NO.	h	t	H	D2
50	50	180	130	105	4	15	14	285	125
65	65	190	155	130	4	15	14	330	140
80	80	200	180	145	4	19	14	380	160
100	100	230	200	165	8	19	16	430	180
125	125	250	235	200	8	19	16	495	200
150	150	270	265	230	8	19	18	560	224
200	200	290	320	280	8	23	20	680	280
250	250	330	385	345	12	23	22	800	355
300	300	370	430	390	12	23	22	920	400
350	335	410	480	435	12	25	24	1000	450
400	380	470	540	495	16	25	24	1100	500

尺寸表 SIZE TABLE (7366)

DN	d	L	D	C	NO.	h	t	H	D2
50	50	200	155	120	4	19	16	300	140
65	65	220	175	140	4	19	18	350	160
80	80	230	185	150	8	19	18	400	180
100	100	250	210	175	8	19	18	450	200
125	125	270	250	210	8	23	20	520	224
150	150	290	280	240	8	23	22	580	250
200	200	310	330	290	12	23	22	700	315
250	250	340	400	355	12	25	24	840	400
300	300	380	445	400	16	25	24	960	450
350	335	370	490	445	16	25	26	1050	500
400	380	410	560	510	16	27	28	1150	560

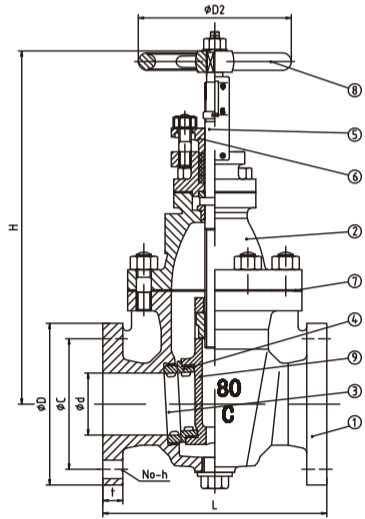

铸钢球形防浪阀 F3060 Cast Steel Globe Storm Valves
铸钢角式防浪阀 F3060R Cast Steel Angle Storm Valves

材料表 MATERIALS TABLE

序号	零件名称	材料		NAME OF PART	MATERIAL	
		CLASS B	CLASS S		CLASS B	CLASS S
1	阀体	ZG230-460		BODY	SC450	
2	阀盖	ZG230-460		BONNET	SC450	
3	阀杆	HPb59-1	ZG2Cr13	STEM	C4641 BD OR 4641BE	SUS420
4	密封圈	丁腈橡胶		GASKET	NBR	
5	垫片	丁腈橡胶		GASKET	NBR	
6	手柄	HT200		HANDWHEEL	FC200	

尺寸表 SIZE TABLE (3060)

DN	H	D	C	n-d	I
50	210	130	105	4-15	250
65	240	155	130	4-15	250
80	260	180	145	4-19	250
100	280	200	165	8-19	250
125	330	235	200	8-19	250
150	360	265	230	8-19	250
200	450	320	280	8-23	250

尺寸表 SIZE TABLE (3060R)

DN	H1	H2	D	C	n-d	I
50	170	90	130	105	4-15	250
65	200	110	155	130	4-15	250
80	220	120	180	145	4-19	250
100	250	130	200	165	8-19	250
125	270	150	235	200	8-19	250
150	310	165	265	230	8-19	250
200	400	190	320	280	8-23	250

